

---

# Use and maintenance manual

EVERLASTING

BLAST CHILLERS/SHOCK FREEZERS

# KING TROLLEY

**Thank you for choosing this product.**

Please read the warnings contained in this manual carefully, as they provide important information regarding safe operation and maintenance.

Make sure to keep this manual for any future reference by the various operators.

In some parts of the manual, the  symbol appears, indicating an important warning that must be observed for safety purposes.

## CHAPTER 1 BOUNDARY CHARACTERISTICS OF OPERATION

The blast chiller has been designed and built to operate in optimal conditions at temperatures of up to +43°C , with adequate air circulation. In places with characteristics that are different from the requirements, the stated performance cannot be guaranteed.

The supply voltage must be 400N/3Ph/50Hz as standard, or as indicated on the EC label.

The following table shows the cooling and/or freezing capacity in kg.

Model	Blast chilling +90°C / +3°C	Rapid freezing +90°C / -18°C
<b>KING TROLLEY 20 L / P</b>	80 Kg. / 110 Kg.	60 Kg. / 85 Kg.
<b>KING TROLLEY 40 L / P</b>	150 Kg. / 220 Kg.	120 Kg. / 170 Kg.
<b>KING TROLLEY 80 L / P</b>	340 Kg. / 420 Kg.	280 Kg. / 330 Kg.
<b>KING TROLLEY 120 L / P</b>	420 Kg. / 630 Kg.	330 Kg. / 480 Kg.

**N.B.:** the times and quantities in kg above are valid for products with a maximum thickness of 4 cm.

**Maximum time: Positive chilling: 90 min, Freezing: 240 min**

The blast chiller complies with the European directives as described in detail in the Annex “**EC Declaration of Conformity**”

The data are reported on the EC label placed on the blast chiller. For the models KING TROLLEY 20 at the upper back, for the models KING TROLLEY 40-80-120 sideways of the instrument panel.

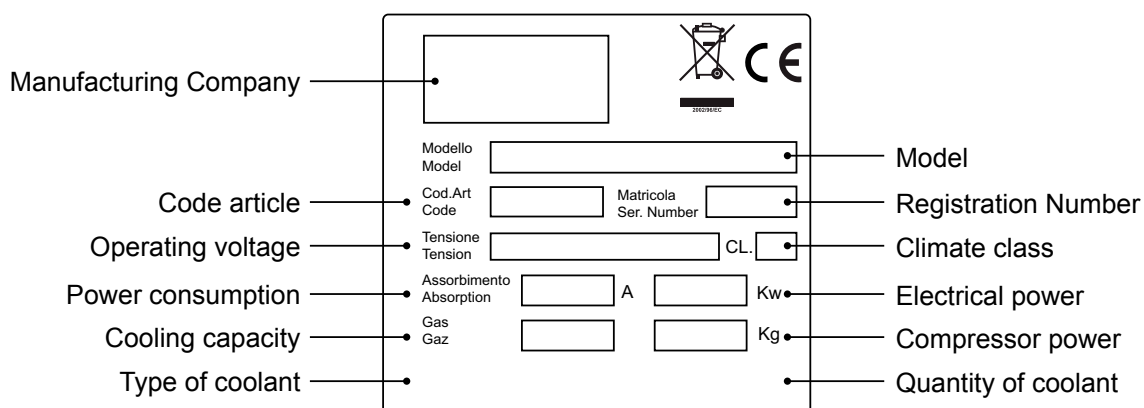

The manufacturer declines any liability for improper use of the blast chiller, as well as use that could not have been reasonably foreseen, and for all operations performed on it that disregard the instructions in the manual.



**ATTENTION:** The main general safety standards are listed below:

- **Do not** use or place electrical devices inside the refrigerated compartments if they are not of the type recommended by the manufacturer
- **Do not** touch the blast chiller with damp or wet hands or feet
- **Do not** use the blast chiller barefoot
- **Do not** insert screwdrivers or other objects between the guards or moving parts
- **Do not** pull the power cord to unplug the blast chiller from the electricity network
- the blast chiller **is not** intended to be used by persons (including children) with physical or mental problems, or lack of experience and knowledge, unless they are controlled or instructed in using the unit by a person responsible for their safety. Children must be supervised to ensure that they do not play with the appliance.
- before carrying out any cleaning or maintenance, disconnect the blast chiller from the mains power supply by turning off the main switch and pulling the plug
- in the event of failure and/or malfunction of the blast chiller, turn it off and to refrain from any attempt to repair or intervene directly. It is necessary to exclusively contact a qualified technician.

The blast chiller is composed of a modular monocoque coated with different materials and insulated with polyurethane foam of density 42 kg/m<sup>3</sup>.

In the design and construction, all measures have been adopted to ensure a blast chiller that complies with safety and hygiene requirements, such as: rounded interior corners, deep drawing with drain on the outside for the condensate liquids, no rough surfaces, fixed guards on moving or dangerous parts.

The products must be stored in observance of the load limits given in the table, in order to ensure an efficient circulation of air inside the blast chiller.

<b>Load capacity</b>		
<b>KING TROLLEY 20 L 1 / P 1</b>	2 x 20 GN 1/1 1 x 20 GN 2/1	1 x 20 EN 60x40 1 x 20 EN 60x80
<b>KING TROLLEY 40 L 1 / P 1</b>	2 x 20 GN 1/1 1 x 20 GN 2/1	2 x 20 EN 60x40 1 x 20 EN 60x80
<b>KING TROLLEY 40 L 2 / P 2</b>	3 x 20 GN 1/1 2 x 20 GN 2/1	2 x 20 EN 60x40 1 x 20 EN 60x80
<b>KING TROLLEY 80 L 1 / P 1</b>	5 x 20 GN 1/1 3 x 20 GN 2/1	4 x 20 EN 60x40 2 x 20 EN 60x80
<b>KING TROLLEY 80 L 2 / P 2</b>	5 x 20 GN 1/1 3 x 20 GN 2/1	4 x 20 EN 60x40 2 x 20 EN 60x80
<b>KING TROLLEY 120 L 1 / P 1</b>	8 x 20 GN 1/1 5 x 20 GN 2/1	7 x 20 EN 60x40 4 x 20 EN 60x80
<b>KING TROLLEY 120 L 2 / P 2</b>	8 x 20 GN 1/1 5 x 20 GN 2/1	7 x 20 EN 60x40 4 x 20 EN 60x80



**The installation must be performed exclusively by a qualified technician**

**1.1 It is prohibited to remove the guards and safety devices**

It is absolutely forbidden to remove safety guards.

The manufacturer disclaims any liability for accidents due to failure to comply with this obligation.

**1.2 Information on emergency operations in the event of fire**

- disconnect the blast chiller from the electrical outlet or cut off the main power supply
- do not use water jets
- use dry chemical or CO2 extinguishers

**CHAPTER 2 CLEANING THE REFRIGERATOR**

Since the blast chiller will be used to store food, cleaning is necessary for hygiene and health protection purposes. The cleaning of the blast chiller has already been carried out at the factory. It is suggested, however, to carry out an additional cleaning of the internal parts before use, making sure that the power cord is unplugged.

**2.1 Cleaning the interior and exterior cabinet**

For this purpose the following are indicated

- the cleaning products: water and mild, non-abrasive detergents. **DO NOT USE SOLVENTS AND THINNERS**
- methods for cleaning: wash the interior and exterior parts with warm water and mild soap or with a cloth or sponge with suitable products
- disinfection: avoid substances that can alter the organoleptic characteristics of the food
- rinsing: cloth or sponge soaked in warm water. **DO NOT USE WATER JETS**
- frequency: weekly is recommended, the user can set different frequencies depending on the type of food being stored.

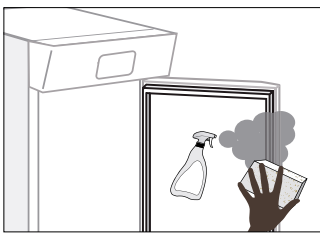

**REMARK :** Clean frequently the door seals.

Some preserved products could release some enzymes that could damage the seals causing its quick deterioration.

For the cleaning, use only specific products for this purposes, available also on request on our sales network.

**2.2 Cleaning the condenser**

The efficiency of the blast chiller is compromised by the clogging of the condenser, therefore it is necessary to clean it on a monthly basis. Before carrying out this operation, switch off the blast chiller unplug the power cord and proceed as follows:

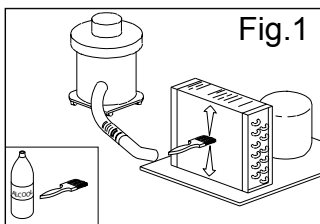

**Remote motocondensing unit**

With the aid of a jet of air or dry brush, eliminate, in a vertical movement (Fig. 1), the dust and lint deposited on the fins. In the case of greasy deposits, we recommend using a brush moistened with special cleaning agents.



During this operation, use the following personal protective equipment: goggles, respiratory protection mask, chemically resistant gloves (gasoline-alcohol).

**CHAPTER 3 PERIODIC CHECKS TO BE CARRIED OUT**

The following are the points or units of the blast chiller that require periodic checks:

- **integrity and efficiency of door seals**
- **integrity of the grilles in contact with food**
- **integrity of the fixing hinges of the doors**
- **integrity of the power cord of the blast chiller and the remote motocondensing unit**

**3.1 PRECAUTIONS IN CASE OF LONG PERIODS OF INACTIVITY**

A long period of inactivity is defined as a stoppage of more than 15 days.

It is necessary to proceed as follows:

- switch off the blast chiller and the remote motocondensing unit and disconnect it from the power supply
- carry out a thorough cleaning of the interior cabinet, shelves, trays, guides and supports, paying special attention to critical points such as the joints and magnetic gaskets, as indicated in Chapter 2.
- leave the door partly open to prevent air stagnation and residual humidity

**CHAPTER 4 PREVENTIVE MAINTENANCE****4.1 Restarting after a long period of inactivity**

Restarting after long inactivity is an event that requires preventive maintenance.

It is necessary to perform a thorough cleaning as described in chapter 2.

**4.2 Control of the warning and control devices**

We recommend that you contact your dealer for a service or maintenance contract that includes:

- cleaning of the condenser of the blast chiller and the remote motocondensing unit
- verification of the coolant load
- verification of the full cycle operation
- electrical safety

**CHAPTER 5 EXTRAORDINARY MAINTENANCE AND REPAIR**

All maintenance activities that have not been described in previous chapters are considered "Extraordinary Maintenance." Extraordinary maintenance and repair are tasks reserved exclusively to the specialist personnel authorized by the manufacturer.

No liability is accepted for actions carried out by the user, by unauthorized personnel, or with the use of non-original replacement parts.

**CHAPTER 6 TROUBLESHOOTING**

Problems may occur, in the blast chiller, identified as shown in the table:

<b>TROUBLE DESCRIPTION</b>	<b>POSSIBLE CAUSES</b>	<b>HOW TO REPAIR IT</b>
<b>the blast chiller does not turn on</b>	no power supply	check the plug, socket, fuses, line
	other	fuses, line
<b>the refrigeration unit does not start</b>	the set temperature has been reached	set new temperature
	defrosting in progress	wait until the end of cycle / turn power off and on again
	control panel failed	contact technical support
	other	contact technical support
<b>the refrigeration unit runs continuously but does not reach the set temperature</b>	location is too hot	aerate more
	condenser is dirty	clean the condenser
	insufficient coolant	contact technical support
	stop the condenser fan	contact technical support
	insufficient sealing of doors	check the seals / provision of goods
	evaporator completely frosted	manual defrosting
	other	contact technical support
<b>the refrigeration unit does not stop at the set temperature</b>	command panel failed	contact technical support
	P1 temperature sensor failed	contact technical support
<b>block of ice on the evaporator</b>	misuse	see chapter 1.
	defrost heater fault	contact technical support
	defrost probe P2 damaged	contact technical support
<b>accumulation of water or ice in the drip tray</b>	drain clogged	clean the pipette and the drain
	blast chiller is not level	check levelling

**CHAPTER 7 INSTRUCTIONS FOR REQUESTING ASSISTANCE**

For any technical problem, and any **requests for assistance or service**, you must exclusively **contact your own dealer** with the code and the registration number described on the label of technical data applied on the equipment

**CHAPTER 8 SAFETY AND ACCIDENT PREVENTION**



**ATTENTION:** The blast chiller has been built with suitable measures to ensure the safety and health of the user.

The following are the measures taken to protect against mechanical risks:

- **stability:** The blast chiller, even with the grilles removed, has been designed and built in such a way that under the intended operating conditions, its stability is suitable for use without risk of overturning, falling or unexpected movement

- **surfaces, edges, corners:** the accessible parts of the blast chiller are, within the limits allowed by their functions, free of sharp angles and sharp edges, as well as rough surfaces likely to cause injury

- **moving parts:** were designed, constructed and arranged to avoid risks. Certain parts are equipped with fixed guards so as to prevent risks of contact which may result in injury.

The following are the measures taken to protect against other risks:

- **electricity:** The blast chiller has been designed, built and equipped so as to prevent risks from electricity, in accordance with the specific legislation in force
- **noise:** The blast chiller has been designed and built in such a way that risks resulting from the emission of airborne noise are reduced to the minimum level

### 8.1 safety devices adopted

It is absolutely forbidden (Fig. 2) :

- to tamper with or remove the closing panels of the monocondensing unit
- remove the labels applied describing the technical characteristics (1) and the warnings for grounding of the blast chiller
- remove the labels applied describing the technical characteristics and the warnings for grounding of the motocondensing unit
- remove the label of the blast chiller which warns the user to turn off the power supply before working on the unit
- remove the label of the remote motocondensing unit which warns the user to turn off the power supply before working on the unit
- to remove the labels applied on the blast chiller indicating grounding
- to remove the labels applied on the remote motocondensing unit indicating grounding
- to remove the label applied on the power cord, indicating the type of power supply (2)

The manufacturer declines any responsibility for the safety of the blast chiller if this were to happen.

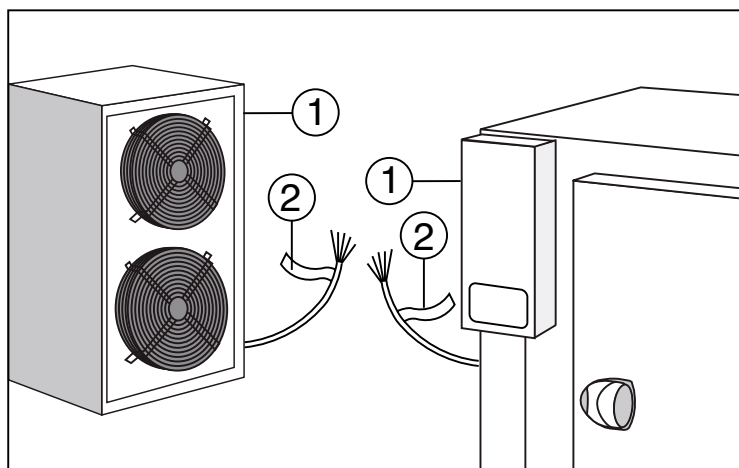

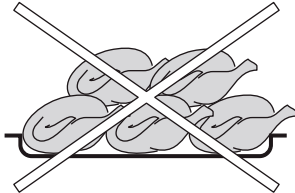

Fig.2

### 8.2 Indications for optimal operation

- do not block the air vents of the remote motocondensing unit
- place the foodstuffs on the appropriate shelves or containers. Do not place them directly on the bottom, or leaning against the walls, doors or fixed guards
- close the doors carefully
- always keep the defrost water drain hole clear of obstructions
- limit, to the extent possible, the frequency and duration of door opening. Each opening causes a change in the internal temperature
- perform periodically current maintenance (see chapter 3)

**Right load of the blast chiller**

Avoid overloading the blast chiller beyond the set limits shown in the table

NO	OK
	

Do not place the trays too close to each other so as to avoid uneven air circulation inside the blast chiller

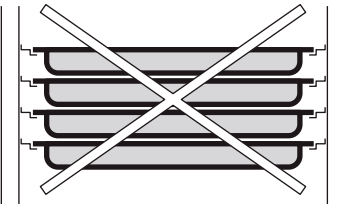
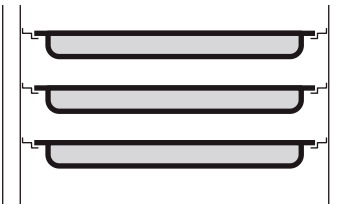
NO	OK
	

Do not place the trays too far away from the evaporator

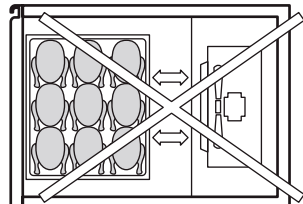
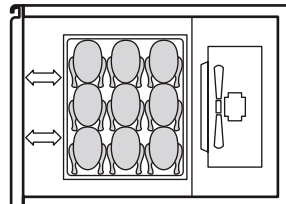
NO	OK
	

Do not concentrate the trays in one area of the blast chiller in case the load is not complete; distribute its height evenly

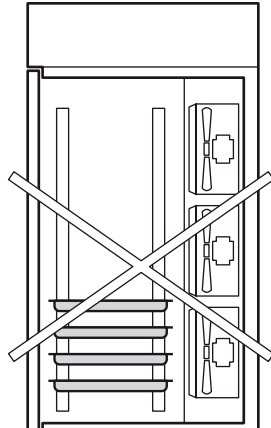
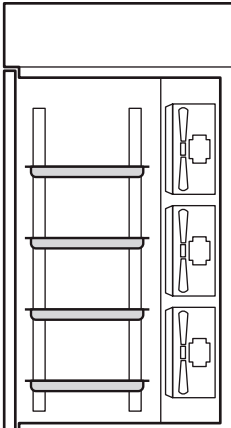
NO	OK
	

In case of interruption or failure of the power supply circuit, prevent the opening of the doors in order to maintain a uniform temperature inside the blast chiller. If the problem persists longer than a few hours it is recommended to move the material to a suitable place.



CHAPTER 9 CONTROLS

9.1 Description of the controls and buttons (Fig. 3)

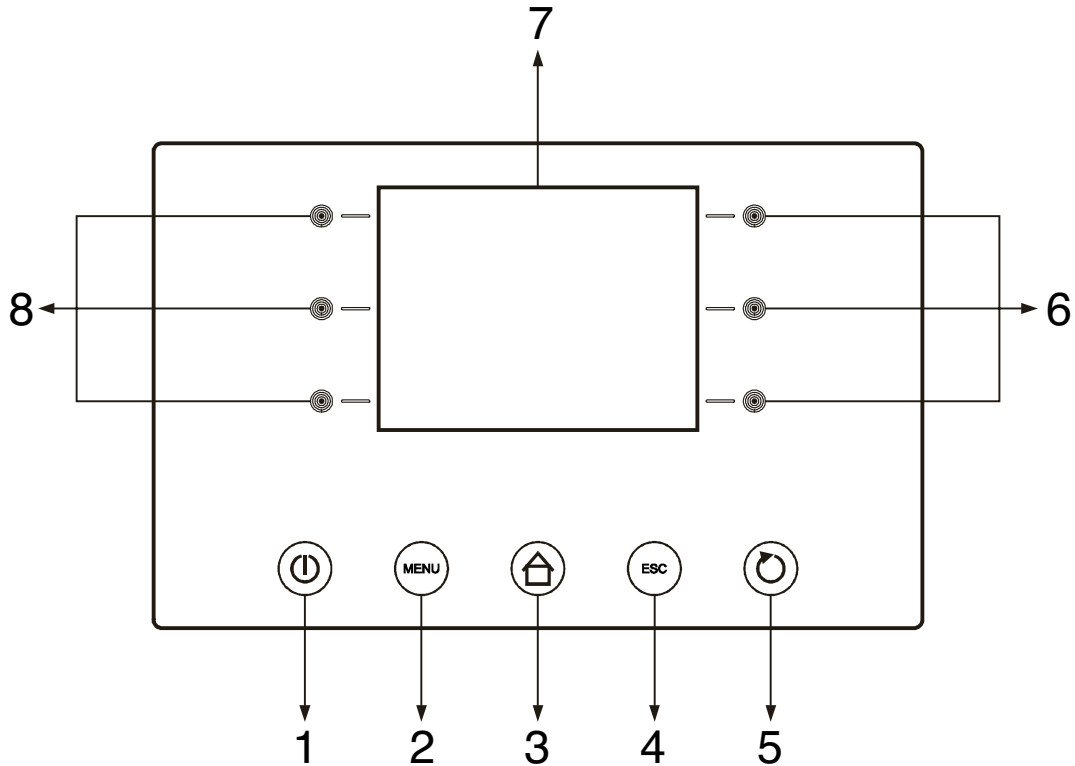









Fig.3

The control buttons with which the blast chiller is equipped are:

 1	On / off push-button, <b>“ON / OFF”</b>
 2	Option push-button, <b>“MENU push-button”</b>
 3	Preset push-button, <b>“HOME push-button”</b>
 4	Cancel push-button, <b>“ESC push-button”</b>
 5	START/STOP push-button , <b>“START / STOP push-button”</b>
 6	Interactive push-button
 7	Display
 8	Interactive push-button

9.2 INSTRUCTIONS FOR USE

9.2.1 Starting

Before starting the temperature blast chiller you need to check if electrical and power connections have been carried out according to what stated at Chapter 17.

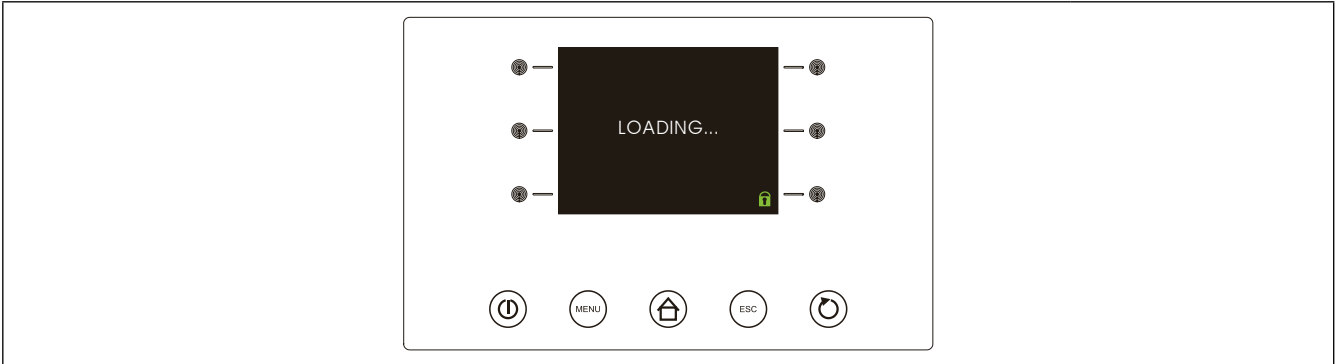

► Connect the machine to power supply: the display is turned off for 10 seconds then it will show the “OFF” mode.

With card in OFF mode:

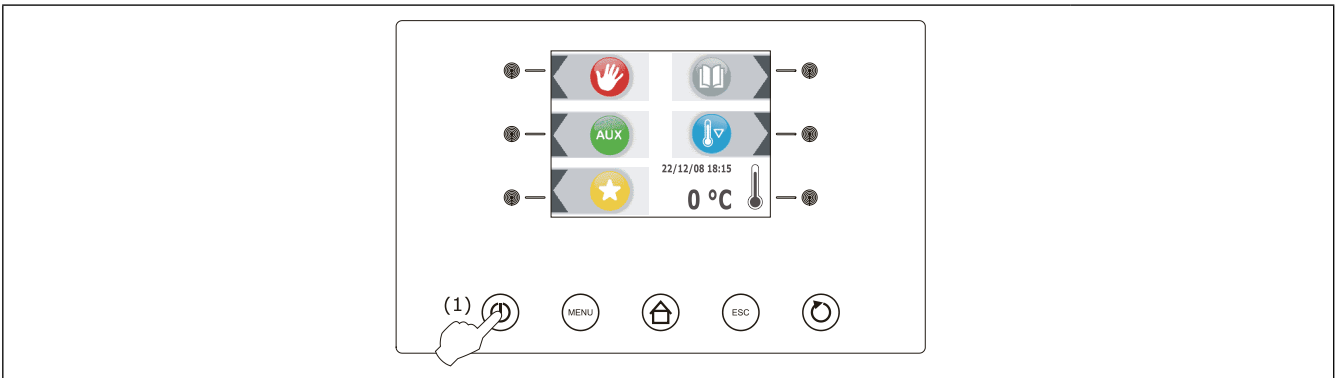

► Press and release the ON / STAND-BY key (1).

► Should the power supply failure cause the clock error (code “rtc”) you need to set date and time again, see paragraph “9.2.2 Internal clock setting: set date and present time”.

Control panel switching On/Off :

Proceed as follows:

- Make sure the keyboard is not locked and no procedure is currently under process.
- Press and release the ON / STAND-BY key (1).

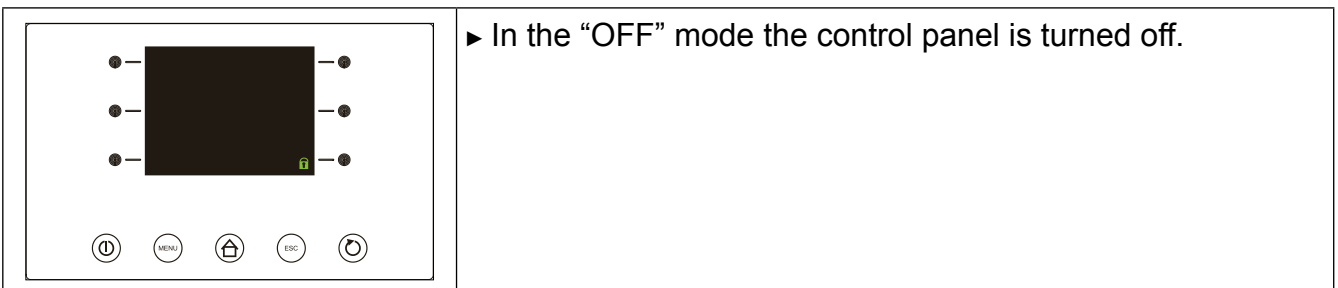

► In the “OFF” mode the control panel is turned off.

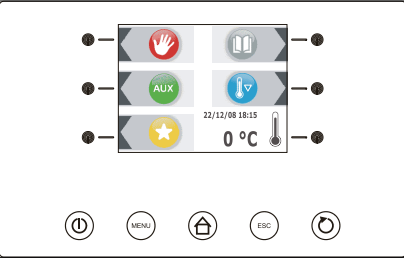
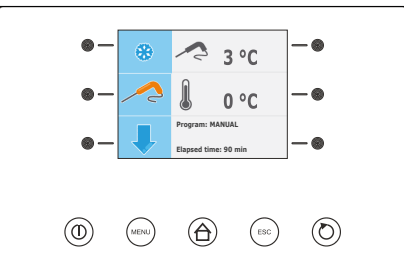
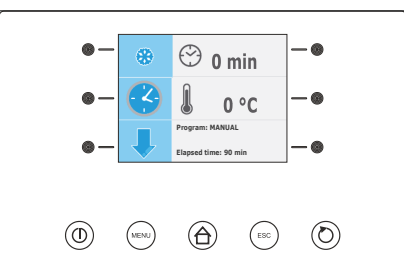
	<p>► In the “ON” and “STAND-BY” modes the control panel will show date, real time and cell temperature.</p>
	<p>► In the “RUN” mode the display will show what follows:          - if a temperature cooling or freezing process is currently under process, the temperature taken by the core probe, the cell temperature, the name of the program (if any) and the time elapsed since the starting of the cooling or freezing process.</p>
	<p>► If a time cooling or freezing process is currently under process, the remaining time of cooling and freezing process, the cell temperature, the name of the program (if any) and the time elapsed since the starting of the cooling or freezing process.</p>

**9.2.2 Internal Clock setting: Set date and present time (fig.3)**

First set the internal clock at present time proceeding as follows:

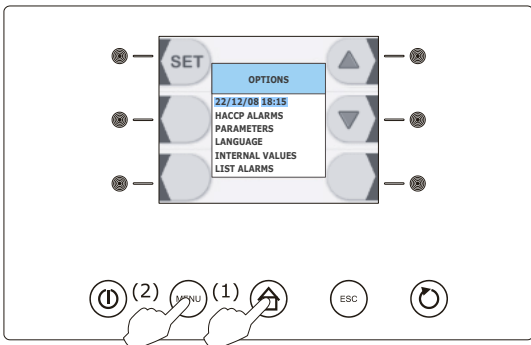

- Make sure the control panel is switched in the “ON” mode.
- Make sure the keyboard is not locked and no procedure is currently under process.

- Press and release the HOME key (1),
- Press and release the MENU key (2), then
- Select the first item of the “CURRENT DATE AND TIME” menu.
- Press and release the key  to enter the adjustment menu

To set current date proceed as follows:

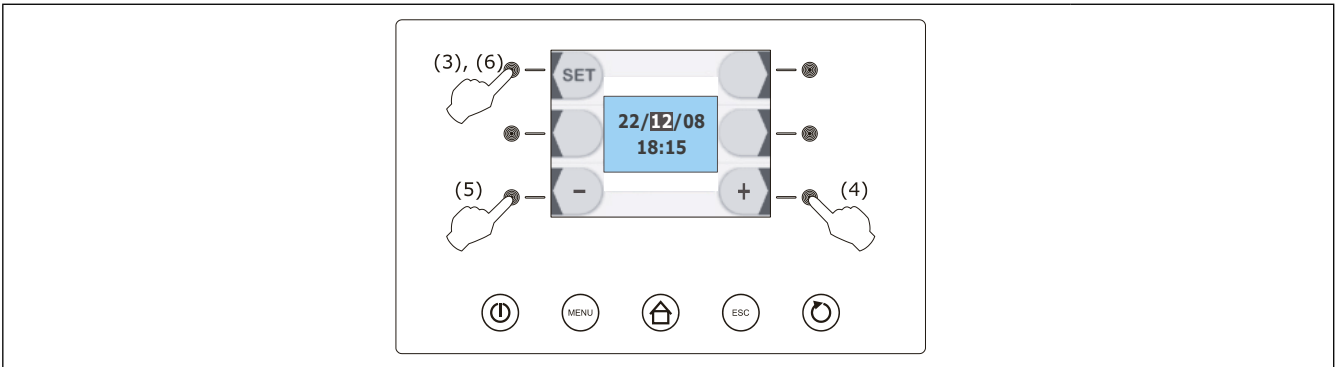

- ▶ Press and release the key or the key to modify the day.
- ▶ Press and release the key to confirm the data entered,

- ▶ Once the date has been set, the control panel will automatically set current year, hours and minutes.
- ▶ Press and release the key or the key to modify the data entered.
- ▶ Press and release the key to confirm the data entered,

Press and release the ESC key to exit from the above procedure or do not work for 60 seconds.

### 9.2.3 Language setting (fig.3)

Proceed as follows:

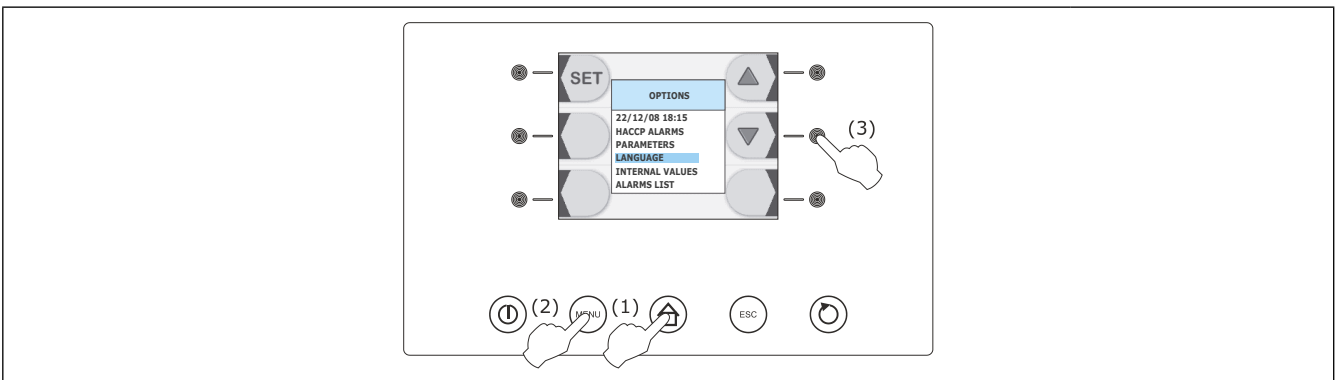

- Make sure the control panel is switched in the “ON” mode.
- Make sure the keyboard is not locked and no procedure is currently under process.

- ▶ Press and release the HOME key (1),
- ▶ Press and release the MENU key (2),
- ▶ Press and release repeatedly the key (3) and select “LANGUAGE”.
- ▶ Press and release the key again .

To select a language proceed as follows:

- ▶ Press and release the key or the key to select the language, then press and release the key again to confirm.

Press and release the ESC key to exit from the above procedure.

#### 9.2.4 Operation

The temperature blast chiller is able to manage the following types of operating cycles:

- ▶ Positive Temperature Cooling with core probe (Par. 9.2.5)
- ▶ **Hard** Positive Temperature Cooling with core probe (Par. 9.2.6)
- ▶ Time Positive Temperature Cooling (Par. 9.2.7)
- ▶ Time **Hard** Positive Temperature Cooling (Par. 9.2.8)
- ▶ **Soft** Positive Temperature continuous cooling (Par. 9.2.9)
  
- ▶ Freezing with core probe (Par. 9.2.10)
- ▶ **Soft** Freezing with core probe (Par. 9.2.11)
- ▶ Time Freezing (Par. 9.2.12)
- ▶ Time **Soft** Freezing (Par. 9.2.13)
- ▶ Continuous **Hard** Freezing (Par. 9.2.14)
- ▶ Precooling (Par. 9.2.15)
- ▶ Fish Sanitization Process (Par. 9.2.18)

We suggest you to carry out the cell precooling process before each and every operating cycle; see paragraph “9.2.15 Precooling”.

The temperature operating cycles are preceded by a test to verify if the core probe has been inserted properly; see paragraph “9.2.16 Test for checking the core probe proper insertion”.

At the end of every operating cycle the system will automatically switch to the preservation phase, except for the continuous cooling and freezing cycles.

It is also possible to perform the following functions:

- ▶ Switching-on of the UV- light used to sterilize the cell (optional) (Par. 9.2.17)

See following paragraphs for further information

 **Please note: All cooling cycles are pre-set on Soft mode** by default so the Hard mode needs to be selected.

 **Please note: all the Freezing cycles are pre-set on Hard mode** by default so the Soft mode needs to be selected .

 **Please note : the Continuous Cooling and Freezing Mode** refers to cycles having an unlimited duration.

**9.2.5 Positive Temperature Cooling with core probe**

The Temperature Cooling and preservation cycle consists of the following two phases:

- ▶ Cooling
- ▶ Preservation

When a phase is over the control panel automatically switches to the next step.

To start a cycle proceed as follows:

	<ul style="list-style-type: none"> <li>▶ Press and release the key  (1),</li> <li>▶ Press and release the key  (2), then press and release the key  (3): until the icon  is lit on the screen </li> </ul>
--	---

The display will show the end-of-cooling temperature and the running temperature during the cooling phase.

- ▶ Press and release the key MENU, then press and release the key or the key to select the end-of-cooling temperature and the running value during the cooling phase, other than the set ones.
- ▶ Press and release the key or the key to change these values then press the ESC key to store them.

	<ul style="list-style-type: none"> <li>▶ Press and release the START / STOP key (1): the test to verify if the core probe has been inserted properly will start; see paragraph “Test for checking the core probe proper insertion”.</li> <li>▶ If the test is completely successful, the cycle starts.</li> <li>▶ The count of the cooling maximum duration will start only if the temperature taken by the core probe is lower than the set temperature.</li> <li>▶ If the test is not successfully completed the buzzer will sound for 5 seconds every 60 seconds and a time cycle will start; see paragraph “Time cooling and preservation”.</li> </ul>
--	--

During the cooling phase the display will show the temperature taken by the core probe, the cell temperature, the name of the program (if any) and the time elapsed since the starting of the cooling process.

- ▶ To stop the cycle proceed as follows : hold the START / STOP key pressed for 3 seconds.

► If the temperature taken by the core probe reaches the end-of-cooling temperature within the cooling phase time limit , the cooling will be successfully completed, the control panel will automatically switch to the preservation phase and the buzzer will sound.

To silence buzzer press and release any key.

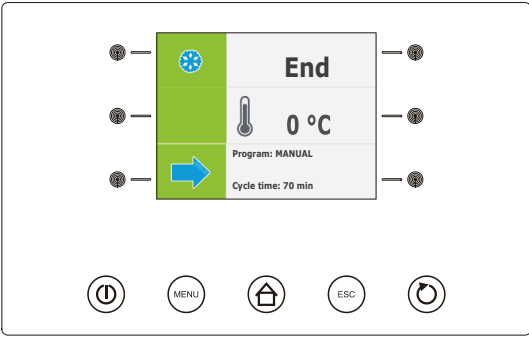
	<p>► During the preservation phase the display will show the cell temperature, the name of the program (if any) and the time taken to complete the cooling phase successfully.</p>
---	--

► If the temperature taken by the core probe does not reach the end-of-cooling temperature within the cooling phase time limit, the cooling process will not be successfully completed but it will go on working and the buzzer will sound.

► To restore the normal display and to silence buzzer press and release any key.

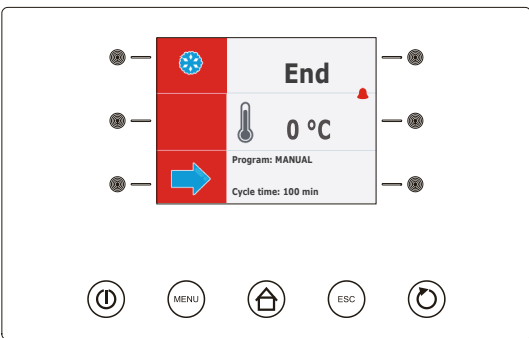
	<p>► When the temperature taken by the core probe reaches the end-of-cooling temperature , the control panel will automatically switch to the preservation phase as stated above.</p>
--	---

**9.2.6 Hard Positive Temperature cooling with core probe**







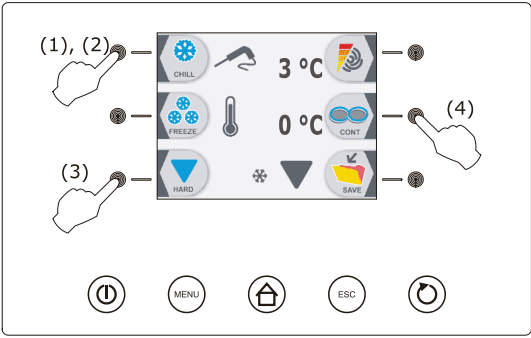

The temperature hard cooling and preservation cycle consists of the following three phases:

- ▶ Cooling hard phase
- ▶ Cooling
- ▶ Preservation





When a phase is over the control panel automatically switches to the next step.

To start the cycle proceed as follows:

- Make sure the display is in the “ON” mode.
- Make sure the keyboard is not locked and no procedure is currently under process.

	<ul style="list-style-type: none"> <li>▶ Press and release the key  (1),</li> <li>▶ press and release the key  (2), then press and release the key  (3) so the display will show the icon  and finally press and release the  (4): key until the icon  is lit on the screen. </li> </ul>
--	---

The display will show the end-of-cooling temperature and the running temperature during the cooling phase.

- ▶ Press and release the MENU key, then press and release the key  or the key  key to select the end-of-cooling temperature and the operating value during the cooling phase, other than the set ones.
- ▶ Press and release the key  or the key  to change these values then press the ESC key to store them.

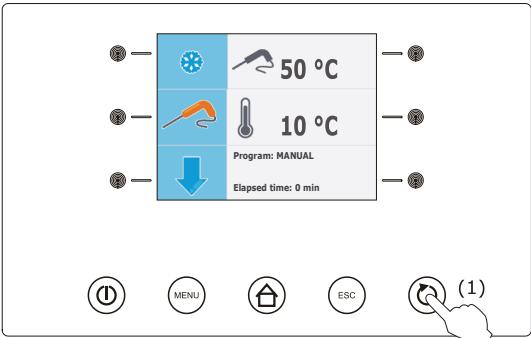
	<ul style="list-style-type: none"> <li>▶ Press and release the START / STOP key (1): the test to verify if the core probe has been inserted properly will start; see paragraph “Test for checking the core probe proper insertion”.</li> <li>▶ If the test is completely successful, the cycle starts.</li> </ul> <p>The count of the cooling time limit will start only if the temperature taken by the core probe is lower than the fixed temperature.</p>
---	--

▶ If the test is not successfully completed the buzzer will sound for 5 seconds every 60 seconds and a time cycle will start; see paragraph “Time hard cooling and preservation”. During the cooling hard phase the display will show the temperature taken by the core probe, the cell temperature, the name of the program (if any) and the time elapsed since the starting of the cooling process.

- ▶ Hold the START / STOP key pressed for 3 seconds to stop the cycle.



When the temperature taken by the core probe reaches the end-of-hard-cooling phase the control panel will automatically switch to the cooling phase.

During the cooling phase, the display will show the temperature taken by the core probe, the cell temperature, the name of the program (if any) and the time elapsed since the starting of the cooling process.

► If the temperature taken by the core probe reaches the end-of-cooling temperature within the cooling phase time limit, the cooling will be completely successful, the control panel will automatically switch to the preservation phase and the buzzer will sound.

► To silence buzzer press and release any key.

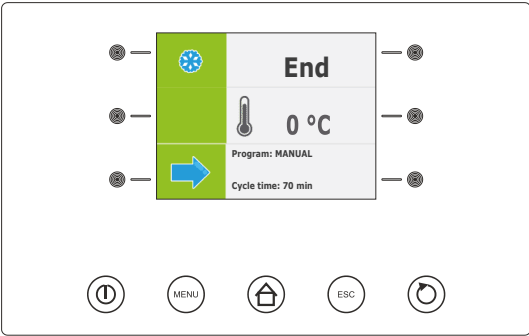
	<p>► During preservation the display will show the cell temperature, the name of the program (if any) and the time taken to complete the cooling phase successfully.</p> <p>► If the temperature taken by the core probe does not reach the end-of-cooling temperature within the cooling phase time limit, the cooling will not be successfully completed but it will go on working and the buzzer will sound.</p> <p>► To restore the normal display and to silence buzzer press and release any key.</p>
--	---

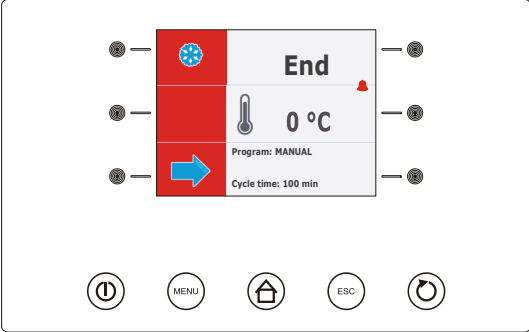
	<p>► When the temperature taken by the core probe reaches the end-of-cooling temperature, the control panel will automatically switch to the preservation phase as stated above.</p>
---	--

### 9.2.7 Time Positive Temperature Cooling

Time cooling and preservation cycle consists of the following two phases:



- Cooling
- Preservation

When a phase is over the control panel automatically switches to the next step. To start the cycle proceed as follows:

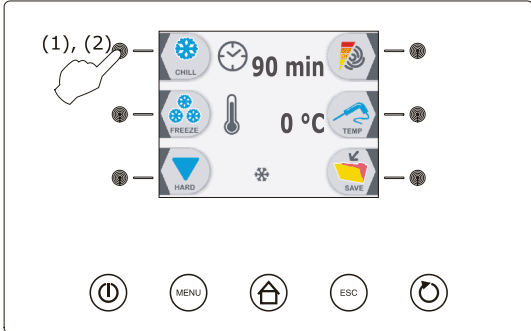

- Make sure the display is in the "ON" mode.
- Make sure the keyboard is not locked and no procedure is currently under process.





(1), (2)

► Press and release the key  (1), then press and release the key  (2):

The display will show the cooling duration and the running temperature during the cooling process

► Press and release the MENU key, then press and release key  or the key  key to select the duration of the cooling phase and the running temperature during the cooling process, other than the set one.

► Press or release the key  or the key  to modify these values then press the ESC key to store them.

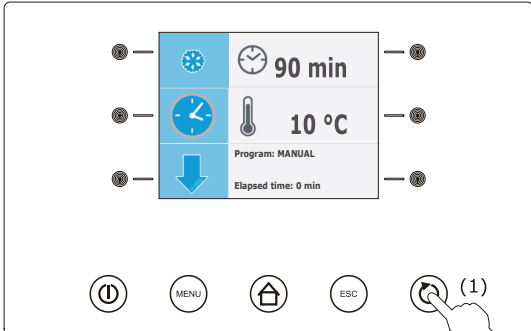

► Press and release the START / STOP key (1) : the cycle will start.

During the cooling phase, the display will show the remaining time of the cooling phase, the cell temperature, the name of the program (if any) and the time elapsed since the starting of the cooling process.

► Hold the START/STOP key pressed for 3 seconds to stop the cycle.

When the cooling phase is over the control panel will automatically switch to the preservation phase and the buzzer will sound.

► To silence buzzer press and release any key.

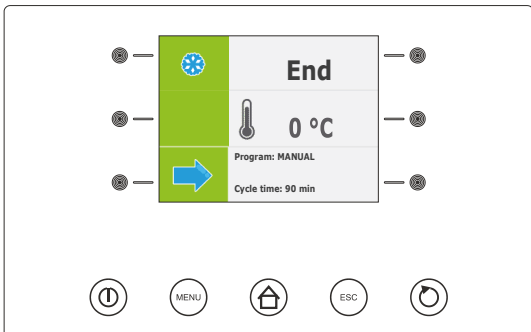

► During preservation the display will show the cell temperature, the name of the program (if any) and the cooling time.





### 9.2.8 Time Hard Positive Temperature Cooling

The time hard cooling and conservation cycle consists of the following three phases:



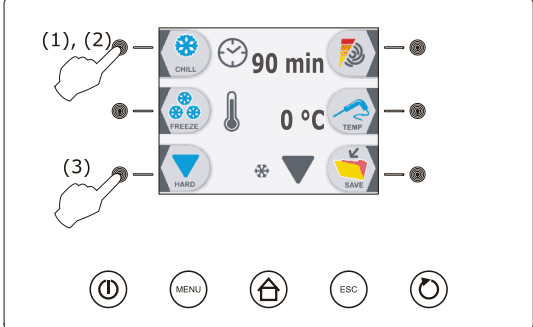

- Cooling hard phase
- Cooling
- Preservation.

When a phase is over the control panel automatically switches to the next step.

To start the cycle proceed as follows:

	<ul style="list-style-type: none"> <li>▶ Make sure the display is in the “ON” mode.</li> <li>▶ Make sure the keyboard is not locked and no procedure is currently under process.</li> <li>▶ Press and release the key  (1), press and release the key  (2), then press and release the key  (3): in order the display mode changes and the display compares it with the symbol .</li> </ul>
---	---

The display will show the duration of the cooling phase and the running temperature during the cooling process.

- ▶ Press and release the MENU key, then press and release the key  or the key  to select the duration of the cooling phase and the running temperature during the cooling process, other than the set one.
- ▶ Press and release the key  or the key  to modify these values then press the ESC key to store them.

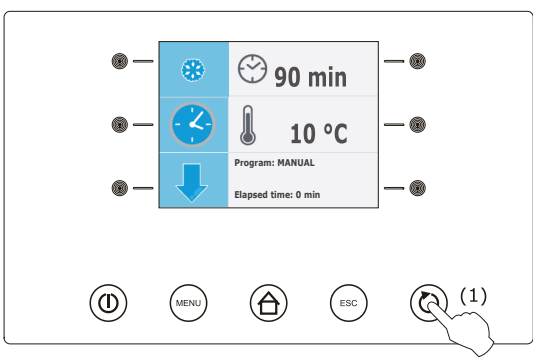
	<ul style="list-style-type: none"> <li>▶ Press and release the START / STOP key (1) : the cycle will start.</li> <li>▶ During the hard cooling phase, the display will show the remaining time of the cooling phase, the cell temperature, the name of the program (if any) and the time elapsed since the starting of the cooling process.</li> <li>▶ Hold the START/STOP key pressed for 3 seconds to stop the cycle.</li> </ul>
--	--

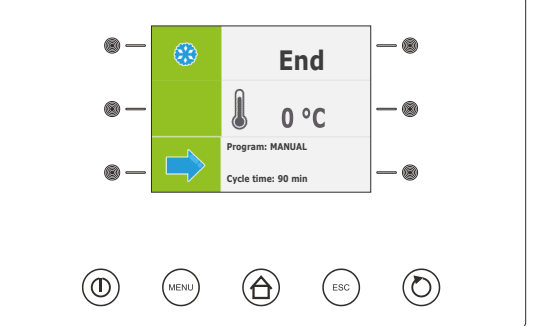

- ▶ When the hard cooling phase is over the control panel will automatically switch to the cooling phase.
- ▶ During the cooling phase the display will show the remaining time of the cooling phase, the cell temperature, the name of the program (if any) and the time elapsed since the starting of the cooling process.
- ▶ When the cooling phase is over the control panel will automatically switch to the preservation phase and the buzzer will sound. To silence buzzer press and release any key.

	<ul style="list-style-type: none"> <li>▶ During the preservation phase the display will show the cell temperature, the name of the program (if any) and the cooling process duration.</li> </ul>
---	--



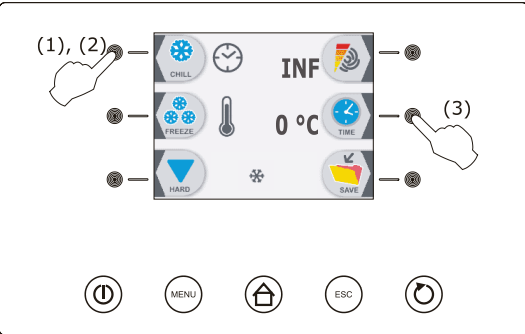

### 9.2.9 Positive Temperature Continuous Cooling

To start the cycle proceed as follows:



- ▶ Make sure the display is in the “ON” mode.
- ▶ Make sure the keyboard is not locked and no procedure is currently under process.
- ▶ Press and release the  (1) key, press and release the  (2) key, then press and release twice the  (3) key: until the icon **INF** appears on the display.

The display will show the running temperature during the cooling process.

- ▶ Press and release the MENU key, then press and release the key  or the key  to select the running temperature during the cooling process, other than the set one.
- ▶ Press and release the key  or the key  to modify this value then press the ESC key to store it.

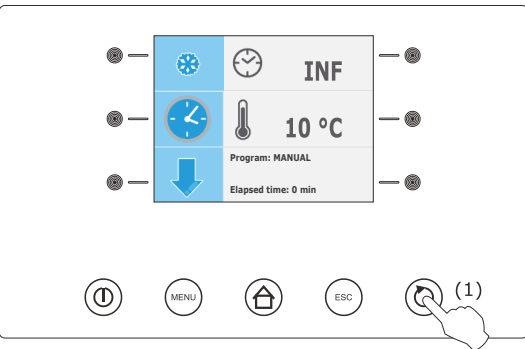

- ▶ Press and release the START / STOP (1) key: the cycle will start.

During the cooling phase, the display will show the cell temperature, the name of the program (if any) and the time elapsed since the starting of the cooling process.

- ▶ Hold the START/STOP key pressed for 3 seconds to stop the cycle.

**9.2.10 Freezing with core probe**

The temperature freezing and preservation cycle consists of the following two phases:

- ▶ Freezing
- ▶ Preservation.

When a phase is over the control panel automatically switches to the next step.  
To start the cycle proceed as follows:

	<ul style="list-style-type: none"> <li>▶ Make sure the display is in the “ON” mode.</li> <li>▶ Make sure the keyboard is not locked and no procedure is currently under process.</li> <li>▶ Press and release the  (1) key, press and release the  (2) key, then press and release the  (3) key in order the icon  appears on the display and finally press and release the  (4) key: in order the icon  “core probe” disappears.</li> </ul>
--	--

The display will show the end-of-freezing temperature and the running temperature during the freezing process.

- ▶ Press and release the MENU key, then press and release the key or the key to select the end-of-freezing temperature and the operating setpoint during the freezing process, other than the set ones.

	<ul style="list-style-type: none"> <li>▶ Press and release the key  or the key  to modify these values then the ESC key to store them.</li> <li>▶ Press and release the START / STOP key (1) : the test to verify if the core probe has been inserted properly will start; see paragraph “Test for checking the core probe proper insertion”.</li> <li>▶ If the test is completely successful, the cycle starts.</li> <li>▶ If the test is not successfully completed the buzzer will sound for 5 seconds every 60 seconds and a time cycle will start; see paragraph “Time freezing and preservation”.</li> </ul>
--	--

- ▶ During the freezing process the display will show the temperature taken by the core probe, the cell temperature, the name of the program (if any) and the time elapsed since the starting of freezing process.
- ▶ Hold the START/STOP key pressed for 3 seconds to stop the cycle.
- ▶ If the temperature taken by the core probe reaches the end-of-freezing temperature within the freezing phase time limit, the freezing will be successfully completed, the control panel will automatically switch to the preservation phase and the buzzer will sound.
- ▶ To silence buzzer press and release any key.

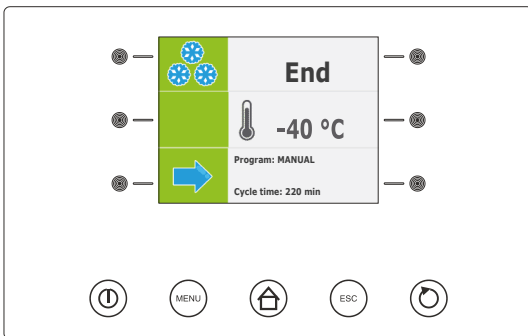

- ▶ During the preservation phase the display will show the cell temperature, the name of the program (if any) and the time taken to complete freezing successfully.

- ▶ If the temperature taken by the core probe does not reach the end-of-freezing temperature within the freezing phase time limit, the freezing will not be successfully completed but it will go on working and the buzzer will sound.
- ▶ To restore the normal display and silence buzzer press and release any key.

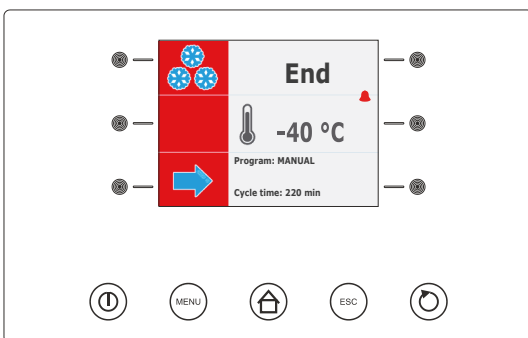

- ▶ When the temperature taken by the core probe reaches the end-of-freezing temperature, the control panel automatically switches to the preservation phase as stated before.

### 9.2.11 Soft Freezing with core probe





The Temperature soft freezing and preservation cycle consists of the following three phases:

- ▶ Freezing soft phase
- ▶ Freezing
- ▶ Preservation.

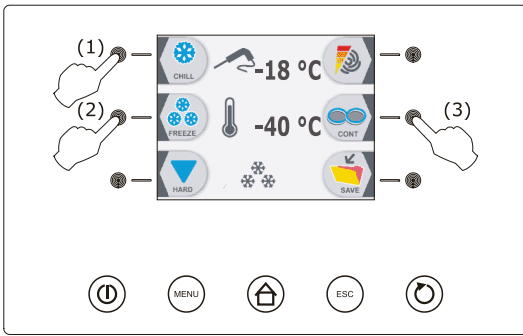



When a phase is over the control panel automatically switches to the next step.

To start the cycle proceed as follows:



- ▶ Make sure the display is in the “ON” mode.
- ▶ Make sure the keyboard is not locked and no procedure is currently under process.
- ▶ Press and release the  (1) key, press and release  (2) key, then press and release  (3) key : in order the icon  “core probe” disappears.

The display will show the end-of-freezing temperature and the running temperature during the freezing process

- ▶ Press and release the MENU key, then press and release the  key or the  key, key to select the end-of-freezing temperature and the operating setpoint during the freezing process, other than the set ones.
- ▶ Press and release the key  or the key  to modify these values, then the ESC key to store them;

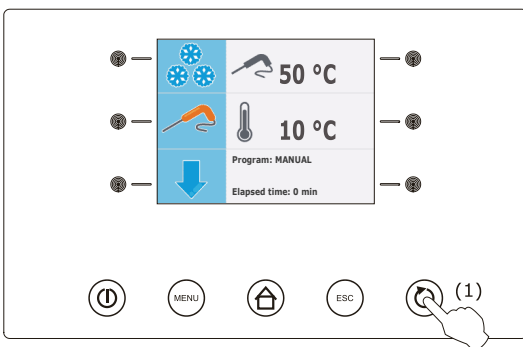

- ▶ Press and release the START / STOP key (1): the test to verify if the core probe has been inserted properly will start; see paragraph “Test for checking the core probe proper insertion”.
- ▶ If the test is completely successful, the cycle starts.
- ▶ If the test is not successfully completed the buzzer will sound for 5 seconds every 60 seconds and a time cycle will start; see paragraph “Time soft freezing and preservation”.
- ▶ During the freezing soft phase the display will show the temperature taken by the core probe, the cell temperature, the name of the program (if any) and the time elapsed since the starting of the freezing process

- ▶ Hold the START/STOP key pressed for 3 seconds to stop the cycle.
- ▶ When the temperature taken by the core probe reaches the end-of-soft-freezing phase, the control panel will automatically switch to the freezing phase.
- ▶ During the freezing phase the display will show the temperature taken by the core probe, the cell temperature, the name of the program (if any) and the time elapsed since the starting of the freezing process.
- ▶ If the temperature taken by the core probe reaches the end-of-freezing temperature within the freezing phase time limit , the freezing will be successfully completed, the control panel will automatically switch to the preservation phase and the buzzer will sound.
- ▶ To silence buzzer press and release any key.

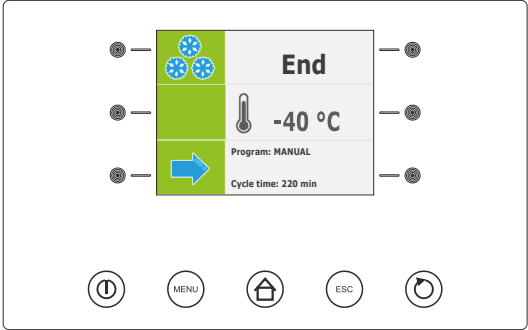
	<p>► During the preservation phase the display will show the cell temperature, the name of the program (if any) and the time taken to complete the freezing successfully.</p>
---	---

► If the temperature taken by the core probe does not reach the end-of-freezing temperature within the freezing phase time limit, the freezing will not be successfully completed but it will go on working and the buzzer will sound.

► To restore the normal display and silence buzzer press and release any key

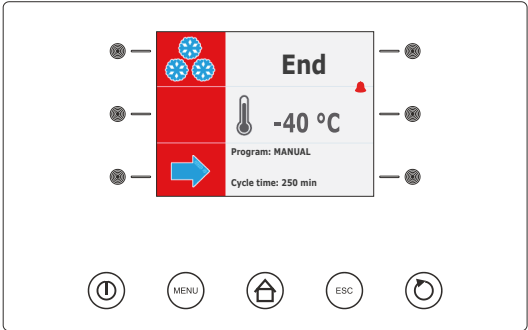
	<p>► When the temperature taken by the core probe reaches the end-of-freezing temperature, the control panel automatically switches to the preservation phase as stated before.</p>
--	---





### 9.2.12 Time Freezing

The Time Freezing and preservation cycle consists of the following two phases:

- Freezing
- Preservation

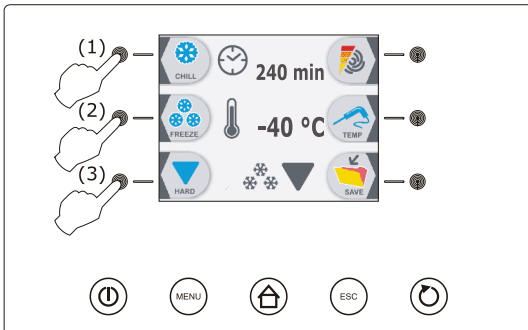

When a phase is over the control panel automatically switches to the next step.



To start the cycle proceed as follows:

	<ul style="list-style-type: none"> <li>► Make sure the display is in the "ON" mode.</li> <li>► Make sure the keyboard is not locked and no procedure is currently under process.</li> <li>► Press and release the  (1) key, press and release  (2) key, then press and release  (3) key : in order the icon  HARD will appear on the display.</li> </ul>
---	--



The display will show the duration of the freezing phase and the running setpoint during the freezing process.

► Press and release the MENU key, then press and release the key  or the key  key to select the duration of the freezing phase running setpoint during the freezing process, other than the set one.

► Press and release the key  or the key  to modify these values, then the ESC key to store them.

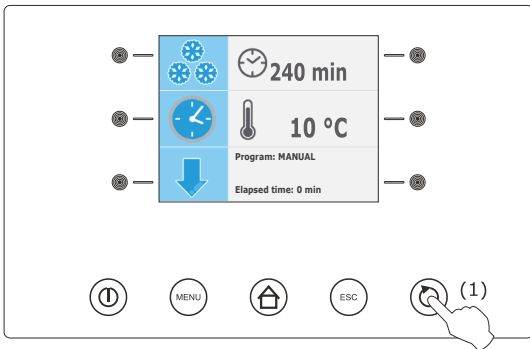

► Press and release the START / STOP (1) key: the cycle will start.

► During freezing the display will show the remaining time of freezing, the cell temperature, the name of the program (if any) and the time elapsed since the starting of the freezing process.

► Hold the START/STOP key pressed for 3 seconds to stop the cycle.

► When the freezing time is over the control panel will automatically switch to the preservation phase and buzzer will sound.

► To silence buzzer press and release any key.

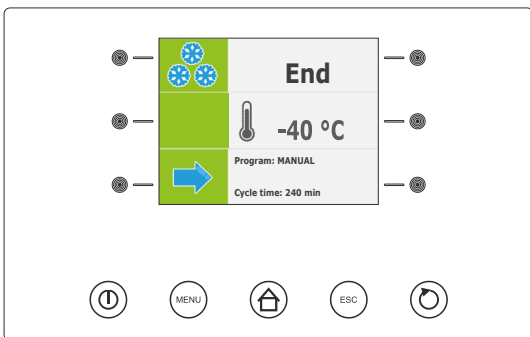

► During the freezing phase the display will show the cell temperature, the name of the program (if any) and the duration of the freezing process.

### 9.2.13 Time Soft Freezing



The Time Soft Freezing and preservation cycle consists of the following three phases:



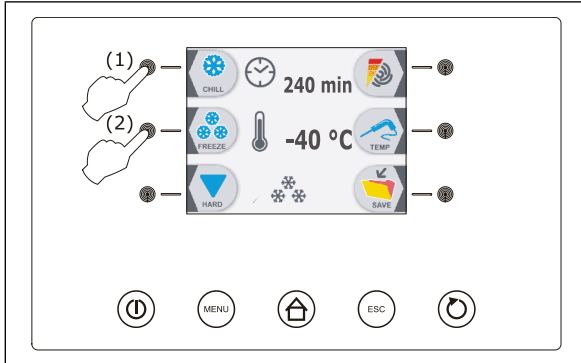

- Freezing soft phase
- Freezing
- Preservation.

When a phase is over the control panel automatically switches to the next step.

To start the cycle proceed as follows:



- ▶ Make sure the display is in the “ON” mode.
- ▶ Make sure the keyboard is not locked and no procedure is currently under process.
- ▶ Press and release the  (1) key, then press and release the  (2) key: the display will show the duration of the freezing phase and the operating setpoint during the freezing process.

- ▶ Press and release the MENU key, then press and release the key  or the key  to select the duration of the freezing phase and the operating setpoint during the freezing process, other than the set ones.
- ▶ Press and release the key  or the key  key to modify these values then the ESC key to save them.

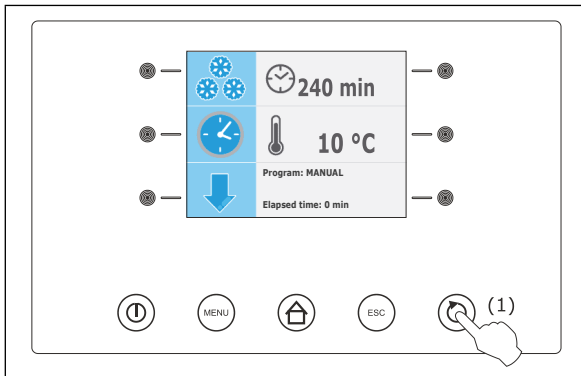

- ▶ Press and release the START / STOP key (1): the cycle will start.
- ▶ During the freezing soft phase the display will show the remaining time of freezing, the cell temperature, the name of the program (if any) and the time elapsed since the starting of the freezing process.

- ▶ Hold the START/STOP key pressed for 3 seconds to stop the cycle.
- ▶ When the freezing soft phase time is over the control panel will automatically switch to the freezing phase.
- ▶ During freezing the display will show the remaining time of the freezing process, the cell temperature, the name of the program (if any) and the time elapsed since the starting of the freezing process.
- ▶ When the freezing time is over the control panel will automatically switch to the preservation phase and buzzer will be sounding. To silence buzzer press and release any key.

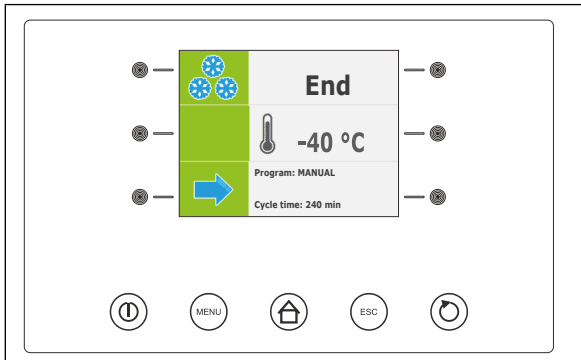

- ▶ During the preservation phase the display will show the cell temperature, the name of the program (if any) and the duration of the freezing process.

### 9.2.14 Continuous Hard Freezing

To start the cycle proceed as follows:

- ▶ Make sure the display is in the “ON” mode.
- ▶ Make sure the keyboard is not locked and no procedure is currently under process.
- ▶ Press and release the (1), press and release the (2) key, then press and release twice the (3) key: until the icon **INF** is shown on the display.
- ▶ The display will show the operating setpoint during the freezing process.

- ▶ Press and release the MENU key, then press and release the key or the key to select the running temperature during the freezing process, other than the set one.
- ▶ Press and release the key or the key to modify this value then the ESC key to save it.

- ▶ Press and release the START / STOP key (1): the cycle will start.
- ▶ During the freezing process the display will show the cell temperature, the name of the program (if any) and the time elapsed since the starting of the freezing process.
- ▶ Hold the START/STOP key pressed for 3 seconds to stop the cycle.

### 9.2.15 Pre-cooling

Each running cycle can be preceded by a precooling process.

To start the precooling cycle proceed as follows:



- ▶ Make sure the display is in the “ON” mode.
- ▶ Make sure the keyboard is not locked and no procedure is currently under process.
- ▶ Press and release the (1) key, then press and release the START / STOP key (2).
- ▶ Hold the START/STOP key pressed for 3 seconds to stop the precooling cycle.

### 9.2.16 Test for checking the core probe proper insertion

Temperature cycles are preceded by a two-phase test to check if the core probe has been properly inserted.



The second phase will be carried out only if the first one has not been successfully completed.

If the test has been successfully completed the cycle starts otherwise the buzzer will be sounding for 5 seconds every 60 seconds and a time cycle will start.

▶ However to start a temperature cycle press the key  or the key  ; after 1 minute since the signal warns that test has not been successfully completed without operating a time cycle will start.

### 9.2.17 Switching-on of the UV light for the sterilization cycle (optional)

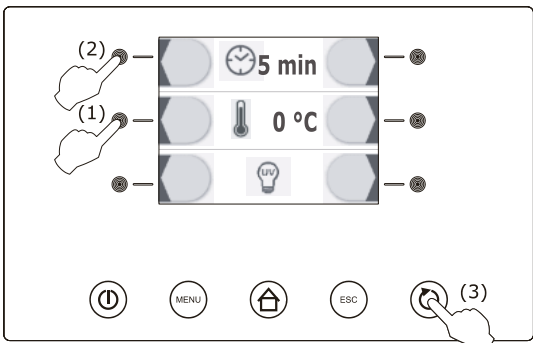
Proceed as follows:

	<ul style="list-style-type: none"> <li>▶ Make sure the display is in the “ON” mode and the door is closed i.e. micro input port is not active.</li> <li>▶ Make sure the keyboard is not locked and no procedure is currently under process.</li> <li>▶ Press and release the  (1) key, press and release the  (2) key, then press and release the START / STOP key (3);</li> </ul>
--	---

The display will show the remaining time of the UV light switching on and the cell temperature.

▶ The UV light is switched on ; the opening of the door, i.e the micro input port is open , causes the light switching off

### 9.2.18 Fish Sanification cycle



This Blast Chiller is provided with a specific program for raw fish sanification with adequate temperature and time. The Fish Sanification program consists of the following three phases:

- ▶ Temperature Freezing with core probe (core probe temperature -20°C)
- ▶ Holding time (core probe temperature -20°C duration: 24 hours)
- ▶ Preservation (cell temperature -22°C unlimited duration)

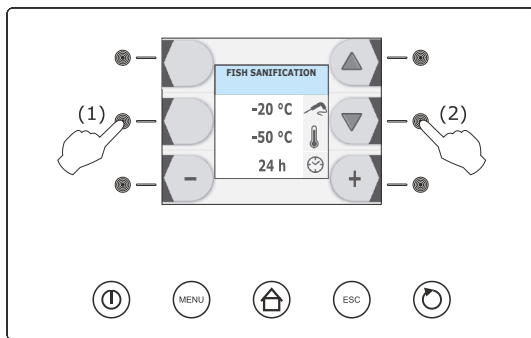

When a phase is over the system automatically switches to the next step.

To start the cycle proceed as follows:



- ▶ Make sure the display is in the “ON” mode.
- ▶ Make sure the keyboard is not locked and no procedure is currently under process.
- ▶ Press and release the  (1) key, then press and release  (2) key:

The display will show the end-of-cooling temperature , the running temperature during the cooling process and the holding time.

- ▶ Press and release the key  or the key  to select these values and press and release key  or the key  to modify them.

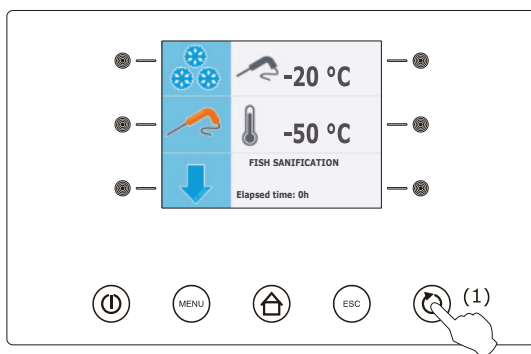

- ▶ Press and release the START/STOP key (1): the test to verify if the core probe has been inserted properly will start; see paragraph “Test for checking the core probe proper insertion”.
- ▶ If the test is successfully completed the cycle starts.
- ▶ If the test is not successfully completed , the buzzer will be sounding, the display will show the “San ALARM” signal and the cycle will be interrupted.
- ▶ To silence buzzer press and release any key.





▶ During the cooling process the display will show the temperature taken by the core probe, the cell temperature and the time elapsed since the starting of the cooling phase.

- ▶ Hold the START/STOP key (1) pressed for 3 seconds to stop the cycle.
- ▶ When the temperature taken by the core probe reaches the end-of-cooling temperature , the cooling process will be completed and the control panel will automatically switch to the holding phase.
- ▶ During the holding phase the end-of-cooling temperature fixes the running temperature during the holding phase, too.
- ▶ When the holding phase is over the control panel will automatically switch to the preservation phase.

### 9.2.19 Defrosting the device

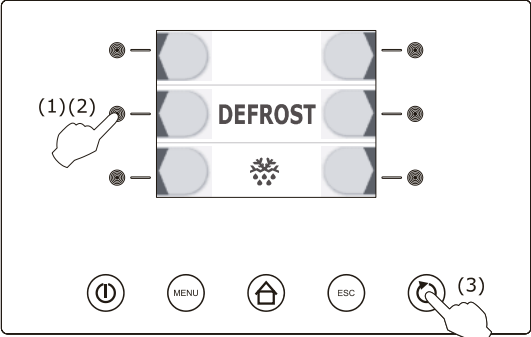
Defrosting is carried out automatically on Trolley blast chiller, only if the evaporator temperature requires it at the end of each chilling or freezing cycle, and every 8 hours during storage cycle.

It is possible to activate a manual defrosting as follows:

	<ul style="list-style-type: none"> <li>▶ Make sure the device is “on” and that either a pre-cooling or a storage but no chilling or freezing cycle is in progress.</li> <li>▶ Push and release key  (1), push and release key  (2), then push and release key  (3).</li> </ul>
---	---

▶ Defrosting will be activated only if the evaporator temperature is lower than the set one (+8); if not, defrosting will not be activated.

CAPITOLO 10 PROGRAMS



**Introduction**

The “Program” function allows you to save settings in a program and start a running cycle using the settings previously saved by Users .  
It is possible to save up to 99 programs.

**10.1 Saving a program**





After selecting the favourite Cooling or Freezing cycle proceed as follows:





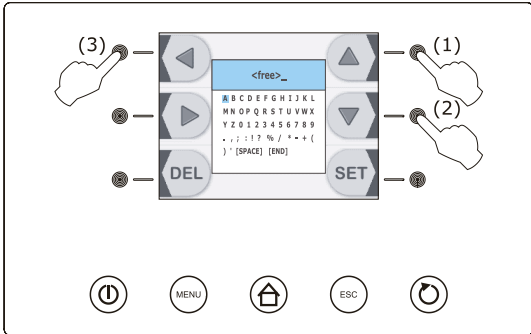





	<ul style="list-style-type: none"> <li>▶ Make sure the keyboard is not locked and no procedure is currently under process.</li> <li>▶ Press and release the  (1) key before starting a running cycle or during a preservation phase: the display will show the number of the first available program.</li> </ul>
--	---

- ▶ If the key  is pressed and released before starting a running cycle, the device will save the following settings:
  - type of selected running cycle
  - cooling/freezing selected intensity
- ▶ If key is pressed before starting a temperature cycle the device will save the following settings:
  - the running temperature during the cooling process and the end-of-cooling temperature.
- ▶ If key is pressed before starting a time cycle the device will save the following settings:
  - The running temperature during the cooling process and the cooling duration.
- ▶ If key  is pressed and released during the preservation phase, the device will save the following settings:
  - Type of current running cycle
  - the cooling or the freezing process duration i.e. the time required to complete the cooling or the freezing phase successfully.
  - the cooling/freezing intensity selected before starting a running cycle.
  - the process temperature selected before starting a running cycle.

## 10.2 Program name



Proceed as follows:

	<p>► Press and release the  (1) key or the  (2) key to select the number of the program then press and release the  (3) key to give it a name.</p>
---	---

- Select letters with , , ,  key then confirm with  key.
- Select “[END]” with , , ,  key and confirm with  key.
- To end procedure press and release the ESC key or do not work for 60 seconds.

## 10.3 Implementation of a program

Proceed as follows:

- Make sure the system is in the “ON” mode.
- Make sure the keyboard is not locked and no procedure is currently under process.
- Press and release the key , press and release key  or key  to select program then press and release the START / STOP key to start it: the running cycle will start according to the settings saved in the program.



**CHAPTER 11 “FAVOURITE” FUNCTION**



**Introduction :**

The “Favourite” function allows you to call up and carry out programs recently performed. It is possible to start up to 99 recent programs.

 **11.1 1 Implementation of a program in the “FAVOURITE” list**

Proceed as follows :

- Make sure the control panel is in the “ON” mode.
- Make sure the keyboard is not locked and no procedure is currently under process.

► Press and release the key , press and release the key  or the key  to select the program, then press and release the START/STOP key to start the program: the running cycle will start according to the settings saved in the program.

**CHAPTER 12 HACCP FUNCTION**

**Introduction**

The “HACCP” function allows you to save up to 9 events for each of the 3 HACCP alarms, then the latest event overwrites the oldest one.

The following table shows the information relative to the HACCP alarms that the system is able to save.

HACCP Alarm	Code	Critical Value	Event Date and Time	Duration
Temperature cooling or temperature freezing not completed within maximum time limit alarm	<b>tiM</b>	Maximum temperature taken by the core probe after temperature cooling or temperature freezing process not completed within maximum time limit.	<b>yes</b>	From 1 min to 99 h and 59 min, partial if alarm is still active
Maximum temperature during preservation alarm	<b>AH</b>	Maximum cell temperature during alarm warning	<b>yes</b>	From 1 min to 99 h and 59 min, partial if alarm is still active
Power supply failure during preservation alarm	<b>PF</b>	Cell temperature when power supply is reset	<b>yes</b>	from 1 min to 99 h and 59 min

Make sure that the control panel is set to “STAND-BY” or “ON” mode before disconnecting power supply to avoid continuously saving of power supply failure alarms (code “PF”).

If the power supply failure alarm duration (code “PF”) causes the clock error (code “rtc”), the control panel will save neither the date nor the time of the alarm signal nor its duration.

## 12.1 HACCP alarms information display

Proceed as follows:

- ▶ Make sure the control panel is in the “ON” mode.
- ▶ Make sure the keyboard is not locked and no procedure is currently under process.
- ▶ Press and release the HOME key (1), press and release the MENU key (2) to select the “HACCP ALARMS”.

- ▶ Press and release the SET (4) key, then press and release the UP (5) key or the DOWN (6) key to select the alarm (the higher is the number following the alarm code the older is the alarm).

- ▶ Press and release the SET key: the display will show the information relating to the alarm.
- ▶ Press and release the UP key or the DOWN key to view the information relative to the previous or to the next alarm.
- ▶ Either press and release the ESC key to exit from the procedure or do not work for 60 seconds.

## 12.2 Deletion of HACCP alarm information

Proceed as follows:

- ▶ Make sure the control panel is in the “ON” mode.
- ▶ Make sure the keyboard is not locked and no procedure is currently under process.
- ▶ Press and release the HOME key (1), press and release the MENU key (2), then press and release the MENU key (3) to select “HACCP ALARMS”.

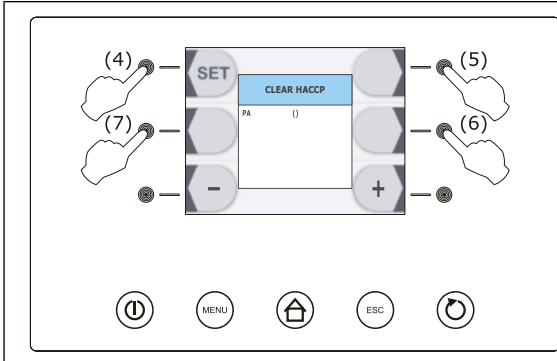

► Press and release the SET (4) key, press and release the (5) key or the (6) key to select the alarm, then press and release the (7) key.

- Repeatedly press and release key to set "149" then press and release key .
- Either press and release the ESC key to exit from the procedure or do not work for 60 seconds.

### 12.3 HACCP record setup

To select the HACCP values to be recorded, operate as follows:

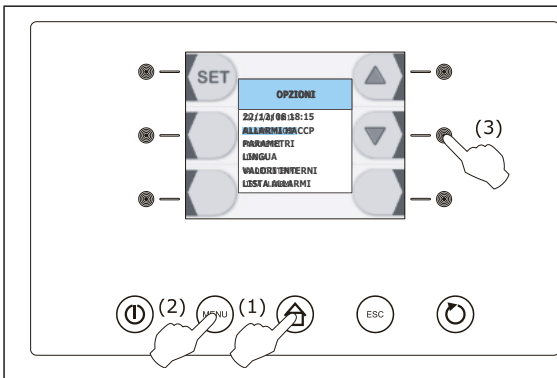

- Make sure the device is "on".
- Make sure that the keyboard is unlocked and that no process is running.
- Push and release HOME (1), push and release MENU (2), then push and release (3) to select "HACCP".

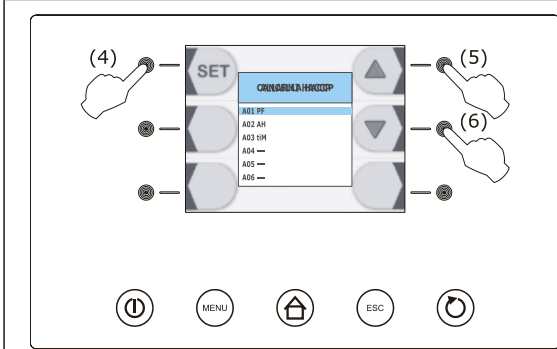

- Push and release (4), then push and release (6) to select "Record Setup".
- Push and release (4) to display HACCP settings

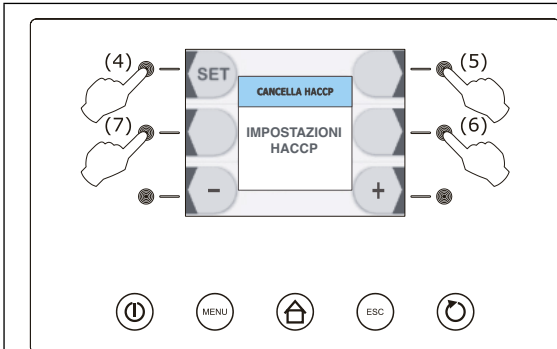

- Push and release (5) or (6) to select the values
- Repeatedly push and release - or + to select or deselect the value to be recorded.

To exit the process, operate as follows: Push and release ESCAPE or do not operate for 60 s

**CHAPTER 13 ALARMS**

This table shows you the alarms which may occur

<b>ALARM</b>	<b>DESCRIPTION</b>	<b>CAUSE</b>	<b>HOW TO SOLVE</b>
<b>Pr1</b>	Cell probe error	• Cell probe is faulty	• Substitute probe
<b>Pr2</b>	Evaporator probe error	• Evaporator probe is faulty	• Substitute probe
<b>Pr3</b>	Condenser probe error	• Disabled	• Disabled
<b>Pr4</b>	Core probe 1 error	• Core probe 1 is faulty	• Substitute probe
<b>Pr5</b>	Core probe 2 error	• Disabled	• Disabled
<b>Pr6</b>	Core probe 3 error	• Disabled	• Disabled
<b>CSd</b>	Blocked compressor alarm	• Disabled	• Disabled
<b>COH</b>	Overheated condenser alarm	• Disabled	• Disabled
<b>rtc</b>	Internal clock error	• The device has not worked for a long time • Control unit is faulty	• Switch on the device and set date again (see par. 9.2.2) • Service
<b>AL</b>	Minimum temperature alarm	• Cell probe is faulty • Control unit is faulty	• Service • Service
<b>AH</b>	Maximum temperature alarm	• Cell probe is faulty • Control unit is faulty • Refrigeration unit is faulty	• Service • Service • Service
<b>tiM</b>	Cooling or freezing phase completed after deadline.	• Insertion of a too hot item • Insertion of a too large item	• Repeat cycle • Repeat cycle
<b>PD</b>	Compressor Poup-Down alarm	• Disabled	• Disabled
<b>PF</b>	Interruption of power supply to the machine	• Power supply failure may have occurred	• Press any key to cancel alarm
<b>Open door</b>	Open door alarm	• The door has been left open for too long time	• Close the door
<b>HP</b>	High pressure alarm	• Disabled	• Disabled
<b>LP</b>	Low pressure alarm	• Disabled	• Disabled
<b>CtH</b>	Compressor thermal protection	• Disabled	• Disabled
<b>ErC</b>	No compatibility between interface and control module error	• Firmware of setting instrument is not compatible	• Service
<b>ErL</b>	No communication between interface and control module error	• Interface connection is either incorrect or faulty	• Check connection
<b>San</b>	Sanification alarm	• Core probe is not properly inserted	• Insert core probe and repeat cycle
<b>CH</b>	Compressor working time	• Compressor working time exceeded	• Plan a maintenance intervention

CAPITOLO 14 USB DOOR



**ATTENTION:** by inserting a USB key you may have the possibility to carry out the following functions:

- ▶ Download data relative to performed cycles to USB key (historical records)
- ▶ Download the saved parameters to USB key (service)
- ▶ Download the saved programs to USB key (service)
- ▶ Upload the parameters contained in the USB key (service)
- ▶ Upload the programs contained in the USB key (service)

**14.1 Download data relative to performed cycles to USB key (historical records)**

<p>▶ If ON put the card in OFF mode by pressing the ON/OFF key (1).</p> <p>▶ Insert the USB key into the USB host port</p> <p>▶ Select with the UP-DOWN keys (9-10) the item of the DOWNLOAD HISTORY menu then press the SET key (11)</p>	
<p>▶ Select with the – and + keys (8-11) date and time</p> <p>▶ Press the SET key (9) to confirm</p>	
<p>▶ Press the START/STOP key (5) to download data relative to performed cycles to USB key.</p> <p>▶ When the operation is over take out the USB key. This option saves a text file (CSV) onto the USB key that may be displayed on any type of PC supplied with EXCEL program.</p>	

The downloaded file will be a CSV format, i.e. it can be simply open with a double click by any computer supplied with Excel program.

The recorded data file have a sequential number according to the number of downloads. In this way the name of the file may vary from “log00n00001.csv” to “log00n00002.csv” and so on. All the acquired data will be automatically reported in an Excel table , separated in columns and lines, thus allowing to draw tables and charts (see the example) according to your requirements.

EVFTFT818			Cell Probe	Core probe
			°C	°C
12/03/2015 14.00	Start		19	19
	State cycle	In progress		
	Type of cycle	Manual		
	Number of phase	Heating		
	Defrost cycle	Off		
	Status compressor	Off		
	State light	Off		
	State humidifier	Off		
	State dehumidifier	Off		
	State defrosting	Off		
	State desistance	Off		
	State steam generator	Off		
12/03/2015 14.02	Event		20	20
	High Press. alarm	Present		
12/03/2015 14.03	Event		20	20
	High Press. alarm	Not present		
12/03/2015 14.05	sampling		20	20
12/03/2015 14.08	event		20	20
	High Press. alarm	Present		
12/03/2015 14.08	event		20	20
	High Press. alarm	Not present		
12/03/2015 14.09	Event		20	20
	Thermal probe	Present		
12/03/2015 14.09	Event		20	20
	Thermal probe	Not present		
12/03/2015 14.10	Sampling		20	20
12/03/2015 14.11	Stop		20	20
12/03/2015 14.11	Start		20	20
	State cycle	In progress		
	Type of cycle	Automatic		
	Number of Phase	Phase 1		
12/03/2015 14.16	Sampling		21	21
12/03/2015 14.16	Stop		21	21

### CHAPTER 15 NOISE LEVEL

The blast chiller has been designed and manufactured in a such way that the risks resulting from the emission of airborne noise are reduced to the lowest level (refer to the technical sheets)

### CHAPTER 16 MATERIALS AND FLUIDS USED

The materials in contact or which may come into contact with foodstuffs comply with the relevant directives.

The blast chiller has been designed and built in such a way that these materials can be cleaned before each use.

The refrigerants used R404A conform to the relevant provisions of law (see Table 1).

R404A is a fluorinated gas covered by the Kyoto Protocol with a GWP potential of 3300



The symbol  indicates that this product must not be treated as household waste.

To prevent potential negative consequences for the environment and human health, make sure that this product is properly disposed of and recycled.

For more information regarding the disposal and recycling of this product, please contact your Distributor, after sale Service, or waste treatment Service.



## CHAPTER 17 TRANSPORT AND HANDLING



The transport and handling of the blast chiller must only be done while maintaining the vertical position, observing the markings on the packaging.

**The manufacturer disclaims any liability for problems resulting from transport performed under conditions other than those specified above.**

The accessories of the blast chiller (guides, grilles, trays, remote condensing unit with pipes) are packaged separately and placed inside the unit.

The blast chiller is mounted on a wooden base with screws and packaged with polyethylene, carton, crate or boxes.

Regarding the disposal of the packaging it is necessary to refer to current regulations in your country.



The movement of the blast chiller shall be performed using a fork lift or pallet trucks equipped with suitable forks (length of at least 2/3 of the unit).

The dimensions and masses of the refrigerated cabinets packed are shown in Table 1.

The limits of stackability and the centre of gravity are indicated on the label of the package.

### 14.1 Positioning operations

Since the incorrect positioning of the blast chiller can cause damage to the same, jeopardizing its proper functioning and result in risk to the personnel, the installer must adhere to the following general rules:

- position the remote unit as described in the installation manual
- position the blast chiller keeping a minimum distance of 3 cm from any wall
- the environment must be sufficiently ventilated
- position the blast chiller away from heat sources
- avoid exposure to direct sunlight
- remove the polyethylene, cardboard or wood packaging



Polyethylene is dangerous for children

- remove any accessories with external connections



use protective gloves when handling the wooden packaging and the wooden base.

The presence of splinters may cause damage to your hands

- remove the PVC film applied as a protection to the outer surfaces of the blast chiller
- position the blast chiller using a level ( Fig. 5 )

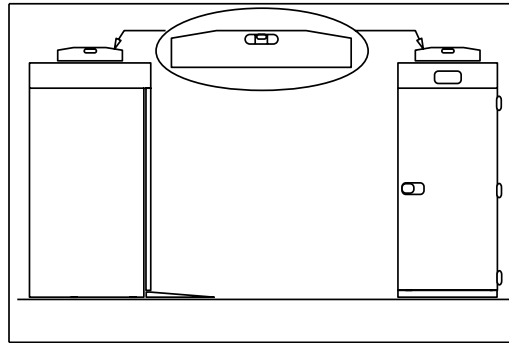

Fig.5

- position the access ramp ( Fig. 6 )

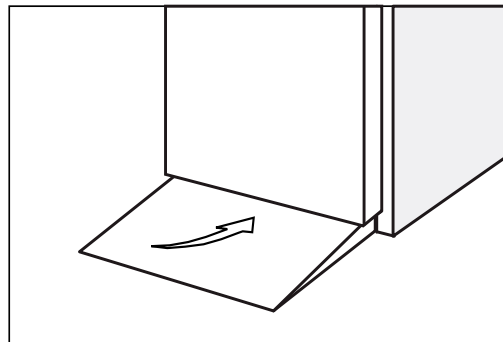

Fig.6

- position the condensing unit ( Fig. 7 )

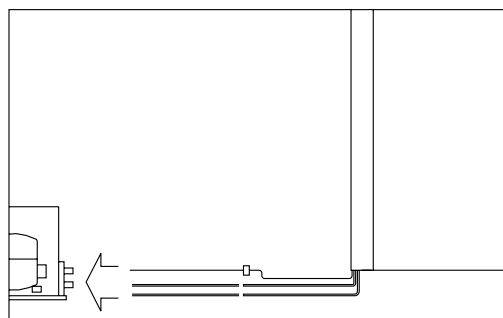

Fig.7

- N.B.: the condensing unit is pre-loaded with nitrogen pressure by the manufacturer
- prepare the two pipes that protrude from the temperature blast chiller for the connection to the respective pipes of the condensing unit
- connect the pipes of the condensing unit to the pipes of the blast chiller
- create a vacuum and then charge of the refrigerant fluid as indicated on the plate or technical data sheet
- make the electrical connection of the blast chiller to the condensing unit (refer to the assembling and installation manual and installation manual of the condensing unit).



**CHAPTER 18 ELECTRICAL WIRING AND CONNECTIONS**

The electrical system and connection must be carried out by qualified personnel. Before installation, measure the impedance of the network, the impedance value for the connection to the network must not exceed 0.075 ohm.

For safety reasons you must follow these guidelines:

- verify that the sizing of the electrical system is suitable for the power consumption of the blast chiller and that it provides for a differential switch (circuit breaker)



The power cord has the connection type “Y” and it can be replaced exclusively by the manufacturer or authorized technical service



It is essential to correctly connect the blast chiller to an efficient earthing system carried out as specified by the applicable provisions of law.

**CHAPTER 19 INSTALLATION OPERATIONS**

It is important, in order to prevent errors and accidents, to perform a series of checks before starting up the blast chiller in order to identify any damage incurred during transport, handling and connection.



**ATTENTION:** Checks to be performed:

- check the integrity of the power cord (it must not have suffered abrasions or cuts)
- check the solidity of the door hinges and inside protections
- check the integrity of the internal and external parts (pipes, heating elements, fans, electrical components, etc.) and their fixing
- check that the seals of the doors and drawers have not been damaged (cuts or abrasions) and close with an airtight seal
- check the integrity of the pipes and fittings

**CHAPTER 20 REINSTALLATION**

It is necessary to comply with the following procedure:

- disconnect the power cord from the power outlet from the condensing unit and from the blast chiller
- the handling should be carried out as described in chapter 17
- for a new placement and connection, please refer to par. 17.1
- proceed to the possible recovery of the refrigerant gas in accordance with the regulations in force in your country.



# **ATTENTION!**

**INSTRUCTIONS RESERVED SOLELY TO TECHNICAL  
PERSONNELL**

Users are adviced that any work performed by non-technical staff or unauthorized personnel will produce the voiding of the warranty rules.



SETTING OF CONFIGURATION PARAMETERS

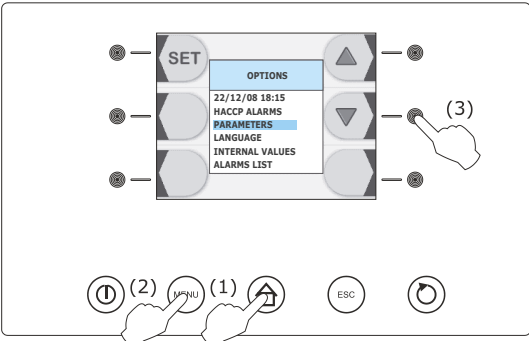

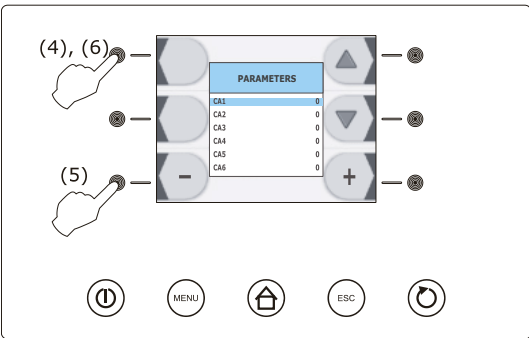

Proceed as follows:



- ▶ Make sure the control panel is in the “ON” mode.
- ▶ Make sure the keyboard is not locked and no procedure is currently under process.
- ▶ Press and release the HOME key (1), press and release the MENU key (2), then repeatedly press and release the  (3) key to select “PARAMETERS”.



- ▶ Press and release  key (4), press and release repeatedly  key (5) and set “-19”, then press and release again  key(6).

- ▶ To select a parameter proceed as follows:
  - press and release the key  or the key .
- ▶ To select a parameter proceed as follows:
  - press and release the key  or the key .
- ▶ To exit from the procedure press and release the ESC key or do not work for 60 seconds.
- ▶ Stop the power supply to the device after setting the configuration parameters.

LIST OF PARAMETERS

Par.	Min.	Mas.	Unit	Default defrost hot gas	Default defrost air	Analog inputs
CA1	-25	25	°C / °F (1)	0	0	cell probe offset
CA2	-25	25	°C / °F (1)	0	0	core probe 1 offset
CA3	-25	25	°C / °F (1)	0	0	evaporator probe offset
CA4	-25	25	°C / °F (1)	0	0	condenser probe offset
CA5	-25	25	°C / °F (1)	0	0	core probe 2 offset
CA6	-25	25	°C / °F (1)	0	0	core probe 3 offset
P0	0	1	----	0	0	tiype of probe 0 = PTC 1 = NTC
P2	0	1	----	0	0	temperature unit of measure (2) 0 = °C 1 = °F

# ENGLISH

P3	0	3	----	1	1	Number of sensors of core probe 0 = core probe not enabled 1 = 1 (core probe1) 2 = 2 (core probe 1 and core probe 2) 3 = 3 (core probe 1, core probe 2 and core probe 3)
P4	0	1	----	1	1	Enable the evaporator probe 1 = yes
P5	0	1	----	0	0	Enable the condenser probe 1 = yes
P8	0	1	----	0	0	Display direction 0 = display is placed higher than the unit 1 = display is placed lower than the unit
Par.	Min.	Max.	Unit	Default	Default	Main Regulator
r0	1	15	°C / °F (1)	3	3	Differential of the r7, r8, r9, r10, r11 and r12 parameters
r1	1	500	min	90	90	time cooling duration
r2	1	500	min	240	240	time freezing duration
r3	-99	99	°C / °F (1)	3	3	Temperature of end-of-temperature-cooling ; temperature of end-of-soft-phase temperature freezing (temperature taken by the core probe); see also the r5 parameter
r4	-99	99	°C / °F (1)	-18	-18	Temperature of end-of-temperature freezing (temperature taken by core probe) ; see also the r6 parameter
r5	1	500	min	90	90	Maximum duration of temperature cooling ; see also the r3 parameter
r6	1	500	min	240	240	Maximum duration of temperature freezing ; see also the r4 parameter
r7	-99	99	°C / °F (1)	-2	-2	Working setpoint during cooling : even working setpoint during the soft phase of soft freezing (cell temperature) ; see also the r0 parameter
r8	-99	99	°C / °F (1)	-40	-40	Working setpoint during freezing (cell temperature); see also the r0 parameter
r9	-99	99	°C / °F (1)	-20	-20	Working setpoint during the hard phase of hard cooling (cell temperature); see also the r0 parameter
r10	-99	99	°C / °F (1)	2	2	Working setpoint during preservation after cooling (cell temperature) ; see also the r0 parameter
r11	-99	99	°C / °F (1)	-22	-22	Working setpoint during preservation after freezing (cell temperature); see also the r0 parameter
r12	-99	99	°C / °F (1)	0	0	Working setpoint during precooling (cell temperature) ; see also the r0 parameter
r13	-99	99	°C / °F (1)	15	15	Temperature of end-of-hard-phase of temperature hard cooling (temperature taken by core probe)
r14	10	100	%	60	60	Duration of the hard phase of time hard cooling (in terms of percentage of the value set with the r1 parameter); even duration of the soft phase of time soft freezing ( in terms of percentage of the value set with the r2 parameter)
r15	-99	199	°C / °F (1)	70	70	Temperature below which the count of the maximum duration of temperature cooling and of temperature freezing starts (temperature taken by core probe)
r16	0	2	----	1	1	Type of running cycle that can be selected 0 = cooling and preservation 1 = cooling and preservation or freezing and preservation 2 = freezing and preservation
r17	0	99	°C / °F (1)	5	5	Minimum difference between "temperature taken by core probe" and "cell temperature" to consider the first phase of the test for checking the proper insertion of core probe successfully completed (you should consider the difference with no sign) 0 = test will not be carried out (neither the first nor the second phase)
r18	1	99	s	60	60	Duration of the second phase of the test for checking the proper insertion of core probe
r19	----	----	----	----	----	reserved
Par.	Min.	Mas.	Unità	Default	Default	Compressor protecting system
C0	0	240	min	1	1	Minimum time interval between the power supply restoration after an interruption occurring during a running cycle and the compressor switching on.
C1	0	240	min	5	5	Minimum time interval between two consecutive switching on of compressor (3)

# ENGLISH

C2	0	240	min	3	3	minimum time interval between the switching off of compressor and the following switching on (3)
C3	0	240	s	0	0	Minimum duration of the compressor switching on
C4	0	240	min	10	10	Duration of the compressor switching off during cell probe error (code "Pr1") occurring during preservation; see also the C5 and C9 parameters
C5	0	240	min	10	10	Duration of the compressor switching on during cell probe error (code "Pr1") occurring during preservation after cooling ; see also the C4 parameter
C6	0	199	°C / °F (1)	80	80	condenser temperature above which the overheated condenser alarm is activated (code "COH") (4)
C7	0	199	°C / °F (1)	90	90	condenser temperature above which the blocked compressor alarm is activated (code "CSd")
C8	0	15	min	1	1	Block compressor delayed alarm (code "CSd") (5)
C9	0	240	min	30	30	Duration of the compressor switching on during cell probe error (code "Pr1") occurring during preservation after freezing; see also the C4 parameter
<b>Par.</b>	<b>Min.</b>	<b>Mas.</b>	<b>Unità</b>	<b>Default</b>	<b>Default</b>	<b>Defrosting (6)</b>
d0	0	99	h	8	0	Defrost time interval (7) 0 = defrost with set time and intervals shall never be activated
d1	0	3	----	1	2	Type of defrost 0 = electric-type (during defrost compressor is switched off, the defrost output is activated and the evaporator fan is switched off) 1 = hot gas-type (during defrost the compressor is switched on, the defrost output is activated and the evaporator fan is switched off) 2 = air-type (during defrost the compressor is switched off and the defrost output is activated; the evaporator fan is switched on independently from the conditions of the door, i.e. Independently from the status of the micro input door) 3 = air-type with open door (during defrost the compressor is switched off and the defrost output is activated; the evaporator fan is switched on provided that the door is open, i.e. The micro input door is active and the i0 parameter is set to values different from 0)
d2	-99	99	°C / °F (1)	8	8	Temperature of end-of-defrost (evaporator temperature) ; see also the d3 parameter
d3	0	99	min	10	30	If the P4 parameter is set to 0, duration of defrost if the P4 parameter is set to 1, maximum duration of defrost; see also the d2 parameter 0 = defrost will never be activated
d4	0	1	----	0	0	Defrost on cooling and freezing starting 1 = yes
d5	0	99	min	1	1	Delayed defrost at preservation starting 0 = defrost is activated after time set with the d0 parameter has passed by.
d7	0	15	min	3	3	Duration of dripping (during dripping compressor and evaporator fan are switched off and the defrost output is deactivated)
d15	0	99	min	0	0	Minimum duration of the compressor switching on upon the defrost starting needed to start defrost (if the d1 parameter is set to 1 only) (8)
d16	0	99	min	0	0	Duration of predripping (if the d1 parameter is set to 1 only; during predripping compressor and evaporator fan are switched off and the defrost output is active)
<b>Par.</b>	<b>Min.</b>	<b>Mas.</b>	<b>Unità</b>	<b>Default</b>	<b>Default</b>	<b>Temperature alarms (9) (10)</b>
A1	0	99	°C / °F (1)	10	10	cell temperature below which the minimum temperature alarm is activated (relative to the working setpoint, i.e. "r10 - A1" during preservation after cooling and "r11 - A1" during preservation after freezing ; code "AL"); see also the A11 parameter (4)
A2	0	1	----	1	1	Enable minimum temperature alarm (code "AL") 1 = yes
A4	0	99	°C / °F (1)	10	10	cell temperature above which the maximum temperature alarm is activated (relative to the working setpoint , i.e. "r10 + A4" during preservation after cooling and "r11 + A4" during preservation after freezing ; code "AH") ; see also the A11 parameter (4)

# ENGLISH

A5	0	1	----	1	1	Enable maximum temperature alarm (code "AH") 1 = yes
A7	0	240	min	30	30	Delayed temperature alarm (code "AL" and code "AH")
A8	0	240	min	30	30	Delayed maximum temperature alarm (code "AH") from the end of evaporator fan stop and from the preservation starting
A10	0	240	min	5	5	duration of power supply interruption such to cause the storage of the power supply failure alarm (code "PF") when it is reset 0 = alarm will not be signalled
AA	0	240	s	5	5	Duration of buzzer activation when cooling and freezing are over
A11	1	15	°C / °F (1)	2	2	Differential of the A1 and A4 parameters
A13	0	1	----	1	1	storage of temperature cooling alarm or temperature freezing not completed within time limit (code "tiM") 1 = yes
A14	----	----	----	----	----	reserved
<b>Par.</b>	<b>Min.</b>	<b>Mas.</b>	<b>Unità</b>	<b>Default</b>	<b>Default</b>	<b>Evaporator and Condenser fan</b>
F0	0	3	----	1	1	Evaporator fan activity during precooling, cooling and freezing (is the parameter is set to 3, this shall apply even during preservation) 0 = off , with digital-type control signal i.e. through digital output K3 1 = on, with digital-type control signal, i.e. through digital output K3; see also the F16 and F17 parameters 2 = parallel to compressor , with digital-type control signal i.e. through digital output K3; see also the F9 and F17 parameters 3 = with analog-type control signal , i.e. through PWM-like digital output and phase cutoff output of speed regulator for single-phase fan EVDFAN1 (to be ordered separately); see also the F18, F19, F20, F21, F22, F23 e F24 parameters
F1	-99	99	°C / °F (1)	10	10	Evaporator temperature above which the evaporator fan is switched off during preservation (if the F0 and/or F2 parameters are set to 3); see also the F8 parameter (11)
F2	0	3	----	2	2	evaporator fan activity during preservation (if the F0 parameter is set to values different from 3 only) 0 = off 1 = on 2 = parallel to compressor; see also the F9 parameter 3 = on ; see also the F1 parameter
F3	0	15	min	0	0	Duration of the evaporator fan stop (during the evaporator fan stop the compressor can be switched on, the defrost output is deactivated and the evaporator fan is off)
F8	1	15	°C / °F (1)	2	2	Differential of the F1, F16 e F17 parameters
F9	0	240	s	15	15	Delayed evaporator fan switching off since the compressor switching off (if the F0 and / or F2 parameters are set to 2 only)
F11	0	99	°C / °F (1)	15	15	condenser temperature above which the condenser fan is switched on (in terms of "F11 + differential and provided that compressor is switched off) ; see also the F12 parameter (4) (12)
F12	0	240	s	30	30	Delayed condenser fan switching off since the compressor switching off (if the P5 parameter is set to 0 only)
F15	0	240	s	0	0	Delayed evaporator fan since the closing of the door i.e.: since the deactivation of the micro input door.
F16	-99	99	°C / °F (1)	70	70	evaporator temperature above which the evaporator fan is switched off during precooling, cooling and freezing (if the F0 parameter is set to 1 only); see also the F8 parameter (11)
F17	-99	199	°C / °F (1)	90	90	cell temperature above which the evaporator fan is switched off during precooling, cooling and freezing (if the F0 parameter is set to 1 or 2 only); see also the F8 parameter
F18	0	100	%	20	20	Speed 1 of the evaporator fan (in terms of percentage of maximum speed; if the F0 parameter is set to 3 only); see also paragraph 6.12 "cooling and freezing intensity"
F19	0	100	%	40	40	Speed 2 of the evaporator fan (in terms of percentage of maximum speed: if the F0 parameter is set to 3 only); see paragraph 6.12 "cooling and freezing intensity"

# ENGLISH

F20	0	100	%	60	60	Speed 3 of the evaporator fan (in terms of percentage of maximum speed; if the F0 parameter is set to 3 only); see paragraph 6.12 "cooling and freezing intensity"
F21	0	100	%	80	80	Speed 4 of the evaporator fan (in terms of percentage of maximum speed; if the F0 parameter is set to 3 only); see paragraph 6.12 "cooling and freezing intensity"
F22	0	100	%	100	100	Speed 5 of the evaporator fan (in terms of percentage of maximum speed; if the F0 parameter is set to 3 only); see paragraph 6.12 "cooling and freezing intensity"
F23	1	5	----	5	5	Speed at which the evaporator fan is switched on during preservation after cooling 1 = speed set with the F18 parameter (speed 1) 2 = speed set with the F19 parameter (speed 2) 3 = speed set with the F20 parameter (speed 3) 4 = speed set with the F21 parameter (speed 1) 5 = speed set with the F22 parameter (speed 5)
F24	1	5	----	5	5	Speed at which the evaporator fan is switched on during preservation after freezing 1 = speed set with the F18 parameter (speed 1) 2 = speed set with the F19 parameter (speed 2) 3 = speed set with the F20 parameter (speed 3) 4 = speed set with the F21 parameter (speed 1) 5 = speed set with the F22 parameter (speed 5)
F25	0	30	min	0	0	Delayed evaporator fan switching on from the compressor switching on to the cooling and freezing starting
<b>Par.</b>	<b>Min.</b>	<b>Mas.</b>	<b>Unità</b>	<b>Default</b>	<b>Default</b>	<b>Digital inputs</b>
i0	0	2	----	1	1	Effect caused by the door opening, i.e. by the activation of the micro input port (13) 0 = no effect 1 = both compressor and evaporator fan are switched off and the cell light is switched on, after the time set with the i2 parameter has passed by, system will show the flashing "id" code and buzzer will be sounding (until the closing of the door); see also the F15 parameter (14) 2 = evaporator fan is switched off and the cell light is switched on, after the time set with the i2 parameter has passed by, system will show the flashing "id" code and buzzer will be sounding (until the closing of the door); see also the F15 parameter.
i1	0	1	----	1	1	Type of contact on the micro input port 0 = normally open (active input with closed contact) 1 = normally closed (active input with open contact)
i2	-1	120	min	5	5	Delayed door open alarm signal (code "id"); after the time set with parameter has passed by, both compressor and evaporator fan are switched off. -1 = alarm is not reported
i5	0	1	----	1	1	Effect caused by the high pressure input activation 0 = no effect 1 = both compressor and evaporator fan are switched off and the condenser fan is switched on, after the time set with the i7 parameter has passed by, system will show the flashing "HP" code and buzzer will be sounding (until input is deactivated).
i6	0	1	----	0	0	Type of contact on the high pressure input 0 = normally open (active input with closed contact) 1 = normally closed (active input with open contact)
i7	-1	240	s	5	5	Delayed high pressure alarm signal (code "HP") -1 = alarm is not reported
i8	0	1	----	0	0	Type of contact on the low pressure input 0 = normally open (active input with closed contact) 1 = normally closed (active input with open contact)

# ENGLISH

i9	-1	240	s	5	5	Delayed low pressure alarm signal (code "LP") -1 =alarm is not reported
i10	0	1	----	0	0	iType of contact on the compressor thermal protection input 0 =normally open (active input with closed contact) 1 =normally closed (active input with open contact)
i11	-1	240	s	5	5	Delayed compressor thermal protection alarm signal (code"CtH") -1 =alarm is not reported
i12	----	----	----	----	----	riservato
<b>Par.</b>	<b>Min.</b>	<b>Mas.</b>	<b>Unità</b>	<b>Default</b>	<b>Default</b>	<b>Digital outputs</b>
u1	0	1	----	1	1	User managed by the K8 output (15) 0 = pump down valve (in this case the u12 parameter is relevant) 1 = alarm output
u5	-99	99	°C / °F (1)	2	2	Cell temperature above which the door resistances are switched off (4)
u6	1	240	min	20	20	Duration of the UV light switching on for each sterilization cycle
u7	-99	199	°C / °F (1)	40	40	End-of-heating temperature of core probe (temperature taken by core probe); see also the u8 parameter
u8	1	240	min	2	2	Maximum duration of core probe heating; see also the u7 parameter
u9	0	1	----	1	1	Core probe heating when door is open, i.e. Activation of the micro input port occurring after the interruption of a cooling and preservation cycle or after a freezing and preservation cycle during preservation 1 = yes
u11	0	1	----	1	1	User managed by the K7 output (15) 0 =cell light (in this case the FREEZING key and the i0 parameter are relevant) 1 =UV light (in this case the FREEZING key and the u6 parameter are relevant)
u12	0	999	s	10	10	Delayed compressor switching off since the pump down valve deactivation (pump down is switching off) (16)
<b>Par.</b>	<b>Min.</b>	<b>Mas.</b>	<b>Unità</b>	<b>Default</b>	<b>Default</b>	<b>Serial communication (serial port RS-485-type with communication protocol MODBUS)</b>
L0	----	----	----	----	----	Reserved
L1	1	240	min	15	15	Data recording intervals during cooling and freezing
L2	1	240	min	60	60	Data recording intervals during preservation
LA	1	247	----	247	247	Device address
Lb	0	3	----	2	2	baud rate 0 = 2.400 baud 1 = 4.800 baud 2 = 9.600 baud 3 = 19.200 baud
LP	0	2	----	2	2	parity 0 = none (no parity) 1 = odd 2 = even
<b>Par.</b>	<b>Min.</b>	<b>Mas.</b>	<b>Unità</b>	<b>Default</b>	<b>Default</b>	<b>Various</b>
E8	0	2	----	0	0	"keyboard block" function activation mode 0 = function not enabled 1 = manual with permanent effect (to block keyboard first make sure no procedure is currently under process then press and release the ON / STAND-BY key, then press and release the highest interactive key on the left; to unblock keyboard repeat the above procedure) 2 = automatic with temporary effect (after 60 second keyboard is automatically blocked ; to unblock keyboard, first make sure that no procedure is currently under process, then press and release the ON / STAND-BY key then press and release the highest interactive key on the left)
E9	0	1	----	0	0	View of splash screen during the passage from the "off" to the "STAND-BY" mode and on power supply reset 1 = yes



ALARM LIST DISPLAYING

Display the alarms and troubleshooting

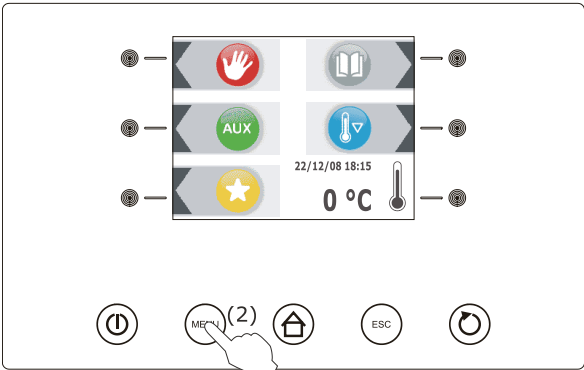
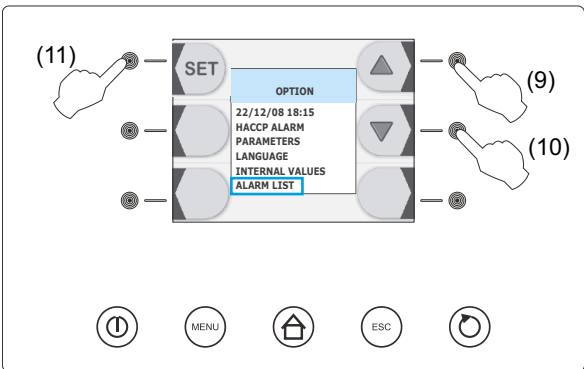
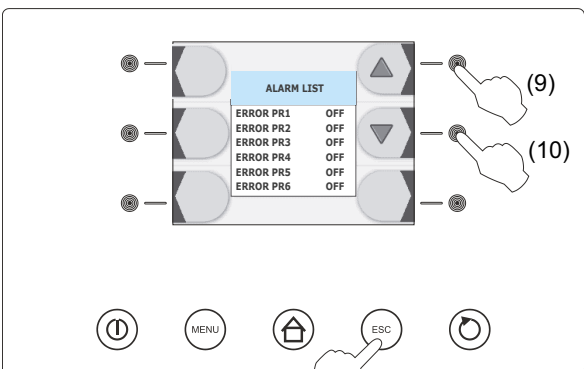
<p>▶ Press key MENU (2),</p>	
<p>▶ Select by keys UP-DOWN (9-10) and ALARM LIST and press key SET (11)</p>	
<p>▶ Press keys UP-DOWN (9-10) to scroll the ALARM LIST</p> <p>▶ Press key ESC (4) to exit or not operate for 60 seconds.</p> <p>The values cannot be modified</p>	

To display the alarm list refer to the chapter 13.

INTERNAL VALUES DISPLAYING

This page will show you all the internal values.

Internal values term refers to the temperature values and the appliance active relays that cannot be modified.

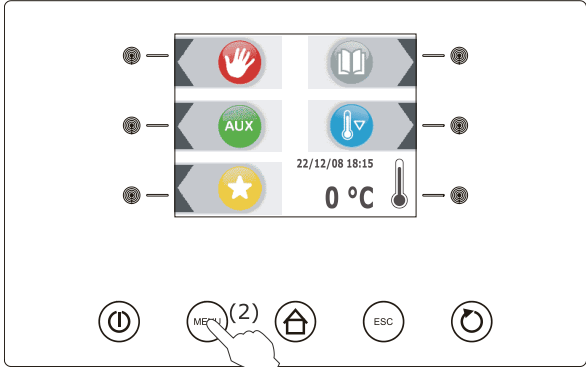
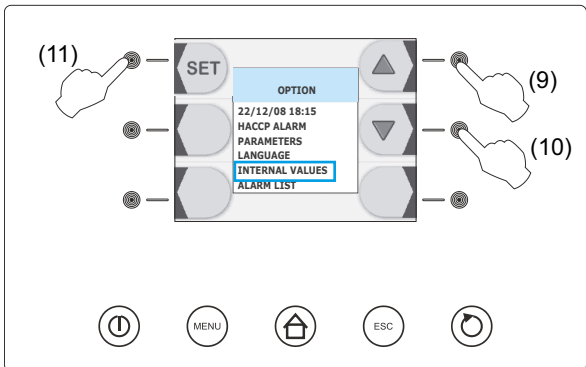
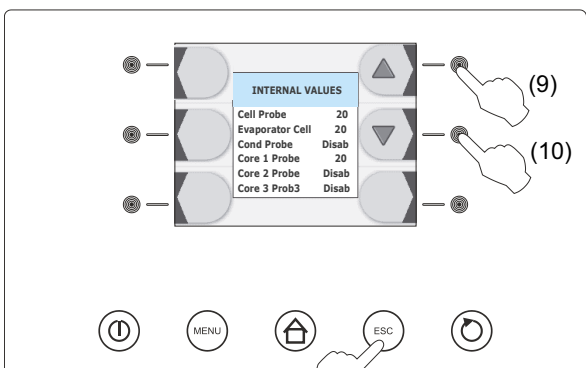
<p>► Press key MENU (2),</p>	
<p>► Select with the UP-DOWN keys (9-10) the "INTERNAL VALUES" item then press the SET key (11)</p>	
<p>► Press the UP-DOWN keys (9-10) to scroll through the INTERNAL VALUES list</p> <p>► Either press the ESC key (4) to exit or do not work for 60 seconds.</p> <p>Values cannot be changed</p>	

INTERNAL VALUES DISPLAYING

DISPLAYING	DESCRIPTION
Cell Probe	• Cabinet/cell probe temperature
Evaporator Cell	• Evaporator probe temperature
Cond. Probe	• Disabled
Core 1 Probe	• Core probe temperature
Core 2 Probe	• Disabled
Core 3 probe	• Disabled
DI door	• Digital input

DI HP	• Disabled
DI LP	• Disabled
DI CTH	• Disabled
DO Comp	• Compressor digital output
DO Fan Evap	• Evaportaor fan digital output
DO Fan Cond	• Disabled
DO Risc Door	• Door resistance digital output
DO Risc Core	• Disabled
DO Light/UV	• Optional germicidal lamp digital output
DO PDown/Alarm	• Alarm digital output
CH	• Compressor working hour-counter

### HISTORICAL DATA

See what stated at Par. 14.1 to download data referring to effected cycles (History) on a USB stick.

### DOWNLOAD OF SAVED PARAMETERS ON A USB STICK

- ▶ When it is ON switch the card on STAND-BY mode by pressing the ON/OFF key (1)
- ▶ Insert the USB stick in the USB port.
- ▶ Select with the UP-DOWN keys (9-10) the “DOWNLOAD PARAMETERS” menu item.

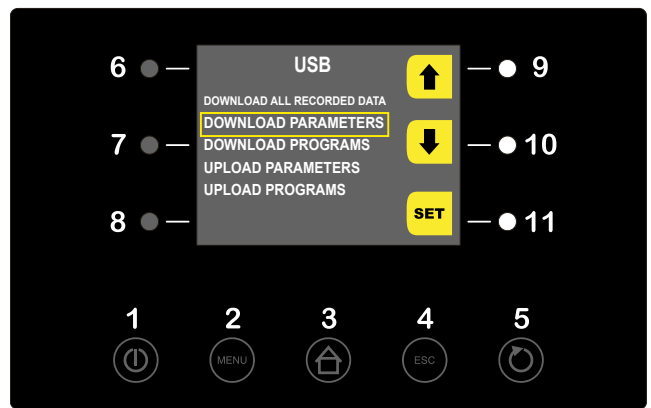

- ▶ Press the SET key (11) to download saved parameters on a USB stick.
- ▶ When the process is over take out the USB stick.

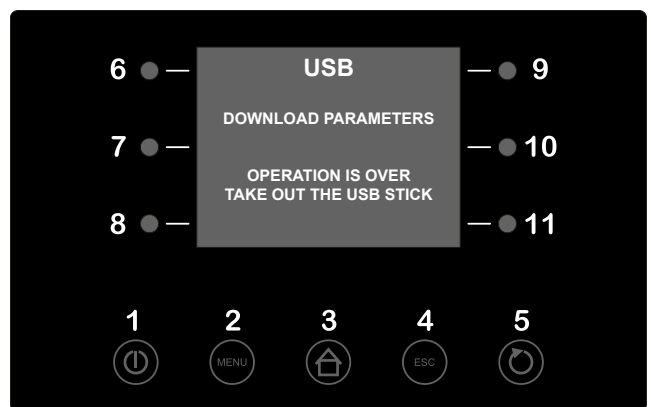

DOWNLOAD OF SAVED PROGRAMS ON A USB STICK

- ▶ When it is ON switch the card on OFF mode by pressing the ON/OFF key (1)
- ▶ Insert the USB stick in the USB port.
- ▶ Select with the UP-DOWN keys (9-10) the "DOWNLOAD PROGRAMS" menu item

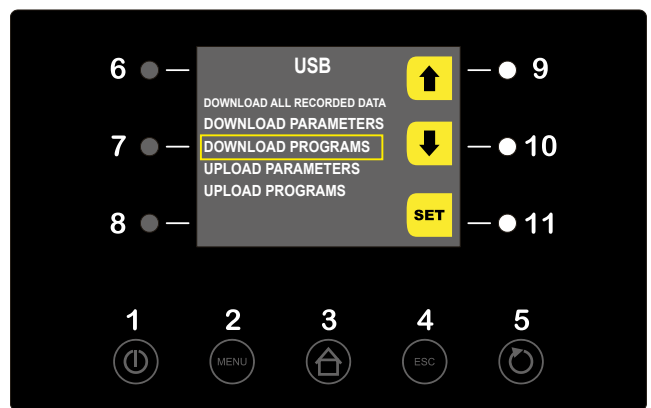

- ▶ Press the SET key (11) to download saved programs on a USB stick.
- ▶ When the process is over take out the USB stick.

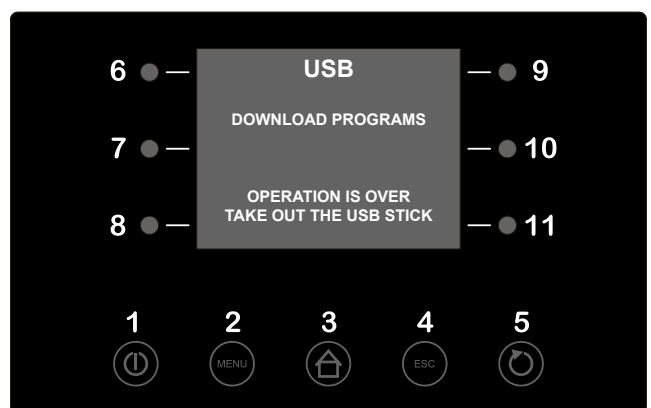

UPLOAD OF SAVED PARAMETERS

- ▶ When it is ON switch the card on OFF mode by pressing the ON/OFF key (1)
- ▶ Insert the USB stick containing the parameters in the USB port.
- ▶ Select with the UP-DOWN keys (9-10) the "UPLOAD PROGRAMS" menu item.

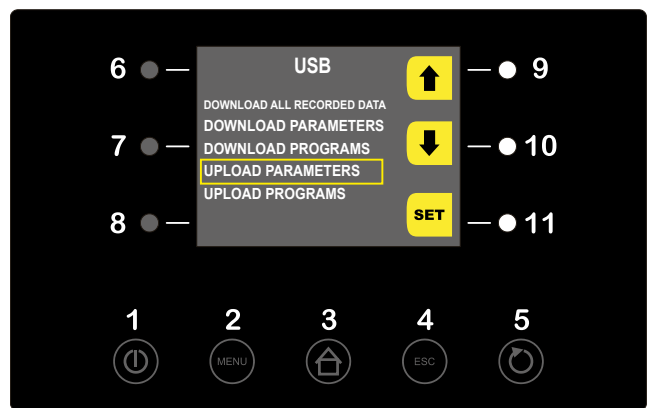

- ▶ Press the SET key (11) to UPLOAD programs.
- ▶ When the process is over, take out the USB stick, switch the voltage off and restart the machine.

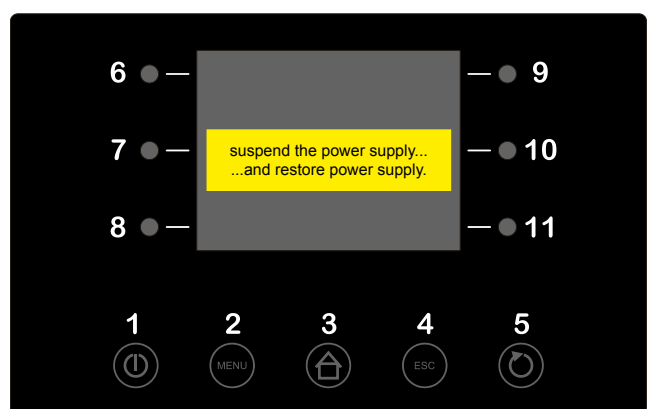

UPLOAD OF SAVED PROGRAMS

▶ When it is ON switch the card on OFF mode by pressing the ON/OFF key (1)

▶ Insert the USB stick containing the parameters in the USB port.

▶ Select with the UP-DOWN keys (9-10) the "UPLOAD PROGRAMS" menu item.

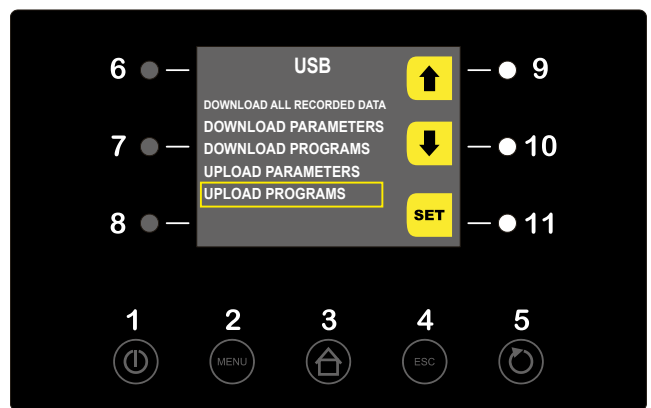

▶ Press the SET key (11) to UPLOAD programs.

▶ When the process is over, take out the USB stick, switch the voltage off and restart the machine.

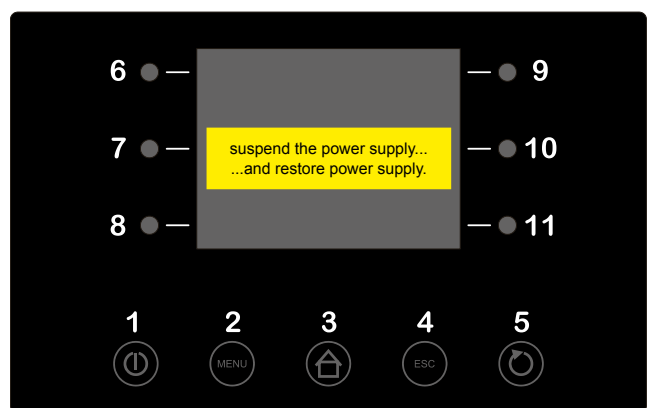

**LEGENDA:**

- M1: terminal board 1 for the connection to the condensing unit
- M2: terminal board 2 for the connection to the cell loads
- PRB1: cell probe
- PRB2: evaporator probe
- PRB3: core probe
- UV: sterilising lamp (optional)
- AL: alarm device by customer
- MP: micro door
- KV: evaorator fan relay
- VE: evaporator fan
- C1-4: fan condenser
- RVC: compensation valve resistance
- RP: door resistance
- RS: condensation drain resistance

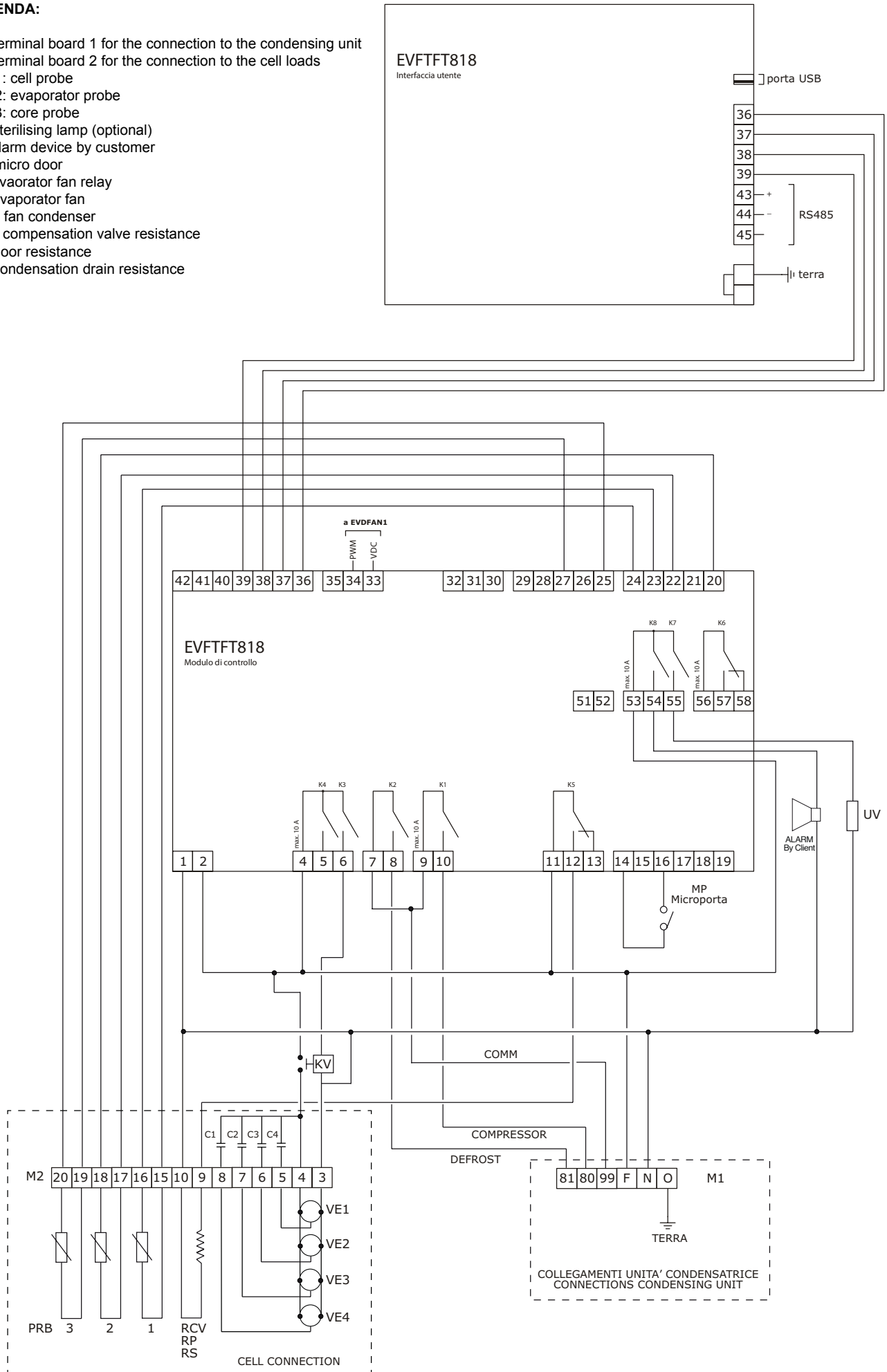

MODELL

TABELLA 1 TABLE 1	Ingombri del armadio imballato Dimensions of the packed cabinet			Peso netto Net weight	peso del materiale imballato shipping weight		Volume depos. Depos. volume	Potenze Powers	
					cartone c.board			Potenza frig. Refrig. power -10°C / +50°C -25°C / +50°C	Assorb. Absorption
mod.	L-W	H	P-D	Kg	Kg	Carrelli - Trolley	watt	Kwatt	
<b>KING TROLLEY</b>									
KING TROLLEY 20 L1	2256	1641	1066	190	240		8140/4120	4,3	
KING TROLLEY 20 L1 SU	2256	1641	1066	190	240	2 x 20 GN 1/1 1 x 20 GN 2/1	8140/4120	0,4	
KING TROLLEY 20 P1	2256	1641	1066	225	275	1 x 20 EN 60 x 40	10380/5240	5,5	
KING TROLLEY 20 P1 SU	2256	1641	1066	225	275	1 x 20 EN 60 x 80	10380/5240	0,5	
KING TROLLEY 40 L1	2680	1700	1500	400	450		15080/7480	7,8	
KING TROLLEY 40 L1 SU	2680	1700	1500	400	450	2 x 20 GN 1/1 1 x 20 GN 2/1	15080/7480	0,45	
KING TROLLEY 40 P1	2680	1700	1500	440	490	2 x 20 EN 60 x 40	21250/9830	10	
KING TROLLEY 40 P1 SU	2680	1700	1500	440	490	1 x 20 EN 60 x 80	21250/9830	0,6	
KING TROLLEY 40 L2	2680	1700	1500	430	480		15080/7480	7,8	
KING TROLLEY 40 L2 SU	2680	1700	1500	430	480	3 x 20 GN 1/1 2 x 20 GN 2/1	15080/7480	0,45	
KING TROLLEY 40 P2	2680	1700	1500	470	520	2 x 20 EN 60 x 40	21250/9830	10	
KING TROLLEY 40 P2 SU	2680	1700	1500	470	520	1 x 20 EN 60 x 80	21250/9830	0,6	
KING TROLLEY 80 L1	2680	1500	1520	720	820		35000/17720	17	
KING TROLLEY 80 L1 SU	2680	1500	1520	720	820	5 x 20 GN 1/1 3 x 20 GN 2/1	35000/17720	1	
KING TROLLEY 80 P1	2680	1500	1520	800	900	4 x 20 EN 60 x 40	40600/21000	21,1	
KING TROLLEY 80 P1 SU	2680	1500	1520	800	900	2 x 20 EN 60 x 80	40600/21000	1,2	
KING TROLLEY 80 L2	2680	1500	1520	735	835		35000/17720	17	
KING TROLLEY 80 L2 SU	2680	1500	1520	735	835	5 x 20 GN 1/1 3 x 20 GN 2/1	35000/17720	1	
KING TROLLEY 80 P2	2680	1500	1520	830	930	4 x 20 EN 60 x 40	40600/21000	21,1	
KING TROLLEY 80 P2 SU	2680	1500	1520	830	930	2 x 20 EN 60 x 80	40600/21000	1,2	
KING TROLLEY 120 L1							40600/21000	22	
KING TROLLEY 120 L1 SU						8 x 20 GN 1/1 5 x 20 GN 2/1	40600/21000	1,5	
KING TROLLEY 120 P1	2680	1000	1520	1020	1120	7 x 20 EN 60 x 40	57500/29100	29,1	
KING TROLLEY 120 P1 SU	+	+	+	+	+	4 x 20 EN 60 x 80	57500/29100	1,8	
KING TROLLEY 120 L2	2680	1500	1520	1030	1130		40600/21000	22	
KING TROLLEY 120 L2 SU	+	+	+	+	+	8 x 20 GN 1/1 5 x 20 GN 2/1	40600/21000	1,5	
KING TROLLEY 120 P2	3720	1500	1520	1150	1250	7 x 20 EN 60 x 40	57500/29100	29,1	
KING TROLLEY 120 P2 SU						4 x 20 EN 60 x 80	57500/29100	1,8	



EVERLASTING s.r.l.  
46029 SUZZARA (MN) - ITALY - S.S. Cisa km.161  
Tel.0376/521800 (4 linee r.a.) - Telefax 0376/521794  
<http://www.everlasting.it> - E-mail:[everlasting@everlasting.it](mailto:everlasting@everlasting.it)